



**TRUE FOOD SERVICE
EQUIPMENT, INC.**



Pizzaovens.com

1.877.FOR.OVEN
367.6836

Since 1999

Project Name: _____

Location: _____

Item #: _____ Qty: _____

Model #: _____

A/A #

SIS #

Model:
TR1HRT-1S-1S

TR Specification Series:
Roll-Thru Solid Door Heated Cabinet



TR1HRT-1S-1S

- ▶ Roll-thru heated cabinet designed to be rear loaded from kitchen prep area and front accessed for quick, efficient food service.
- ▶ Provides cabinet holding temperature of 80°F to 180°F (26.6°C to 82.2°C).
- ▶ Equipped with low-velocity fans to assure even temperature distribution throughout the cabinet. Fans are controlled by exterior on/off switch.
- ▶ Two (2) stainless steel, finned tube heating elements (1000 watts each) for uniform generation of electric heat. Cabinet comes with a total of 2000 watts.
- ▶ 300 series stainless steel exterior front, back, bottom and interior. The very finest stainless; higher tensile strength for fewer dents and scratches.
- ▶ Three (3) lifetime guaranteed, cam-lift hinges per door. Full 180° open capability with a stay open feature at 120°.
- ▶ Designed to accept roll-in racks (inboard castors) with a maximum dimensions of 27" L x 29" D x 66" H (686 mm x 737 mm x 1677 mm). One (1) heavy gauge stainless steel ramp standard per door.
- ▶ Entire cabinet structure and solid doors are foamed-in-place using high density, CFC free, polyurethane insulation.

ROUGH-IN DATA

Specifications subject to change without notice.
Chart dimensions rounded up to the nearest 1/8" (millimeters rounded up to next whole number).

Model	Doors	Capacity (Cu. Ft.) (liters)	Cabinet Dimensions (inches) (mm)			Watts	Voltage	NEMA Config.	Cord Length (total ft.) (total m)	Crated Weight (lbs.) (kg)
			L	D†	H*					
TR1HRT-1S-1S	2	37 1048	35 890	36 ⁷ / ₈ 937	83 ³ / ₄ 2128	2000	115/208-240/60/1	14-20P	9 2.74	400 182

† Depth does not include 4¹/₄" (7 mm) each side for ramps.

* Height does not include 1" (26 mm) for system mechanical components.

Requires 115/208-240/60 Hz, single phase, 3 pole, 4 wire circuit.



1/08

Printed in U.S.A.

APPROVALS:

AVAILABLE AT:

Model:

TR1HRT-1S-1S

TR Specification Series:

Roll-Thru Solid Door Heated Cabinet



STANDARD FEATURES

DESIGN

- True's solid door roll-thru heated cabinets are designed with enduring quality that protects your long term investment.

HEATER SYSTEM

- Cabinet is designed to provide holding temperatures of 80°F to 180°F (26.6°C to 82.2°C). Heating system controlled by exterior on/off switch and temperature control dial.
- Two (2) stainless steel (for corrosion resistance), finned tube heating elements (1000 watts each) for uniform generation of electric heat. Cabinet comes with a total of 2000 watts.
- Equipped with low-velocity fans to assure even temperature distribution throughout the cabinet. Fans are controlled by exterior on/off switch.
- Manually controlled vent located on top of the cabinet for positive humidity control.

CABINET CONSTRUCTION

- Exterior - 300 series stainless steel doors, front, back and bottom. Stainless steel sides.
- Interior - 300 series stainless steel liner and floor.
- Stainless steel breaker caps.
- Insulation - entire cabinet structure and solid doors are foamed-in-place using high density, CFC free, polyurethane insulation.

- One (1) heavy gauge stainless steel ramp standard per door.
- Designed to accept roll-in racks (inboard castors) with a maximum dimensions of 27" L x 29" D x 66" H (686 mm x 737 mm x 1677 mm).

DOORS

- 300 series stainless steel exterior and liner. Doors open within cabinet dimension.
- Door locks standard.
- Lifetime guaranteed recessed door handles. Each door fitted with 12" (305 mm) long recessed handle that is foamed-in-place with a sheet metal interlock to ensure permanent attachment.
- Wiper gaskets for positive seal, reversible.
- Three (3) lifetime guaranteed, cam-lift hinges per door. Full 180° open capability with a stay open feature at 120°.
- Magnetic door gaskets of one piece construction, removable without tools for ease of cleaning.
- Doors are field reversible.

LIGHTING

- Incandescent interior lighting; lights activated by exterior on/off switch, safety shielded.

MODEL FEATURES

- Exterior, color coded, temperature display; accurate direct reading of internal cabinet temperature.
- Designed to hold warm baked or cooked food. Cabinet is not designed to heat ambient or cold product.
- Interior bumpers protect cabinet walls from abuse caused by roll-in carts.
- 12" x 20" (305 mm x 508 mm) pan for water included, if additional humidity is required.
- NSF-4 compliant for open food product.

ELECTRICAL

- True requires that a sole use circuit be dedicated for the unit.
- Unit completely pre-wired at factory and ready for final connection to a 115/208-240/60 Hz. single phase - 20 amp dedicated outlet. Cord and plug set included.



115/208-240/1
NEMA-14-20R

OPTIONAL FEATURES/ACCESSORIES

- Upcharge and lead times may apply.
- Metal door handle (factory installed).
 - Electronic temperature control (factory installed).
 - Correctional facilities options.

PLAN VIEW

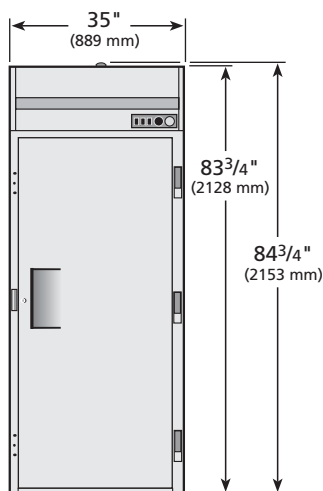

ELEVATION

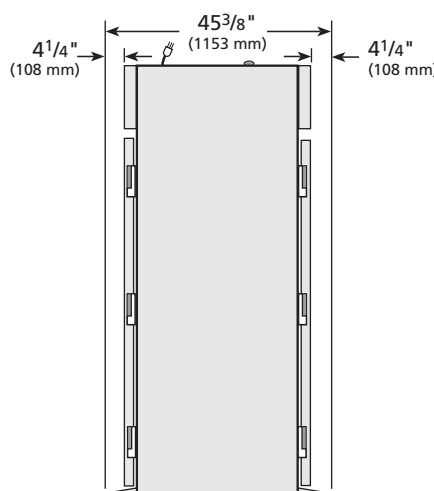

RIGHT VIEW

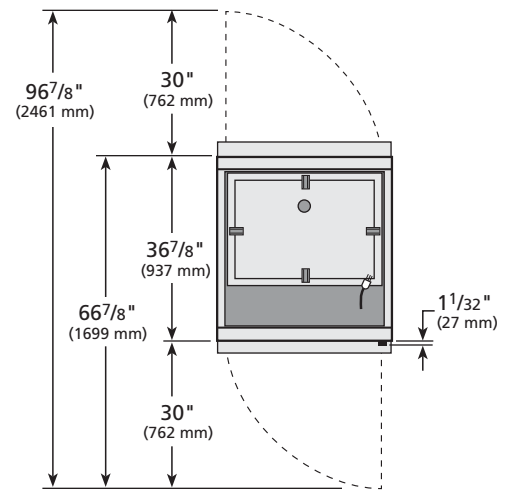

PLAN VIEW

WARRANTY

One year warranty on all parts and labor (U.S.A. only)

METRIC DIMENSIONS ROUNDED UP TO THE NEAREST WHOLE MILLIMETER

SPECIFICATIONS SUBJECT TO CHANGE WITHOUT NOTICE



Model	Elevation	Right	Plan	3D
TR1HRT-1S-1S	TFQY82E	TFQY161S	TFQX61P	TFQY843