



**TRUE FOOD SERVICE
EQUIPMENT, INC.**



Pizzaovens.com

1.877.FOR.OVEN
367.6836

Since 1999

Project Name: _____

Location: _____

Item #: _____ Qty: _____

Model #: _____

A/A #

SIS #

Model:
T-35F

T Series:
Reach-In Solid Door Freezer



T-35F

- ▶ True's solid door reach-in's are designed with enduring quality that protects your long term investment.
 - ▶ Designed using the highest quality materials and components to provide the user with colder product temperatures, lower utility costs, exceptional food safety and the best value in today's food service marketplace.
 - ▶ Extra large evaporator coil balanced with higher horsepower compressor and large condenser maintains -10°F (-23.3°C) cabinet temperatures. Ideally suited for both frozen foods and ice cream.
 - ▶ 300 series stainless steel solid doors and front. The very finest stainless with higher tensile strength for fewer dents and scratches.
 - ▶ Adjustable, heavy duty PVC coated shelves.
 - ▶ Positive seal self-closing doors. Lifetime guaranteed door hinges and torsion type closure system.
 - ▶ Automatic defrost system time-initiated, temperature-terminated. Saves energy consumption and provides shortest possible defrost cycle.
- Bottom mounted units feature:**
- ▶ "No stoop" lower shelf.
 - ▶ Storage on top of cabinet.
 - ▶ Compressor performs in coolest, most grease free area of kitchen.
 - ▶ Easily accessible condenser coil for cleaning.

ROUGH-IN DATA

Specifications subject to change without notice.
Chart dimensions rounded up to the nearest 1/8" (millimeters rounded up to next whole number).

Model	Doors	Capacity (Cu. Ft.) (liters)	Shelves	Cabinet Dimensions (inches) (mm)			HP	Voltage	Amps	NEMA Config.	Cord Length (total ft.) (total m)	Crated Weight (lbs.) (kg)
				L	D	H*						
T-35F	2	35 992	6	39 1/2 1004	29 1/2 750	78 3/8 1991	3/4 3/4	115/60/1 230-240/50/1	12.4 5.5	5-20P ▲	9 2.74	450 205

* Height does not include 5" (127 mm) for castors or 6" (153 mm) for optional legs.

▲ Plug type varies by country.



APPROVALS:

AVAILABLE AT:

Model:
T-35F

T Series:
Reach-In Solid Door Freezer



STANDARD FEATURES

DESIGN

- True's commitment to using the highest quality materials and oversized refrigeration systems provides the user with colder product temperatures, lower utility costs, exceptional food safety and the best value in today's food service marketplace.

REFRIGERATION SYSTEM

- Factory engineered, self-contained, capillary tube system using environmentally friendly (CFC free) R404A refrigerant.
- Extra large evaporator coil balanced with higher horsepower compressor and large condenser; maintains -10°F (-23.3°C). Ideally suited for both frozen foods and ice cream.
- Sealed, cast iron, self-lubricating evaporator fan motor(s) and larger fan blades give True reach-in's a more efficient low velocity, high volume airflow design. This unique design ensures faster temperature recovery and shorter run times in the busiest of food service environments.
- Bottom mounted condensing unit positioned for easy cleaning. Compressor runs in coolest and most grease free area of the kitchen. Allows for storage area on top of unit.
- Automatic defrost system time-initiated, temperature-terminated. Saves energy consumption and provides shortest possible defrost cycle.

CABINET CONSTRUCTION

- Exterior - 300 series stainless steel front. Anodized quality aluminum exterior ends, back and top.
- Interior - attractive, NSF approved, white aluminum liner. 300 series stainless floor with coved corners.

- Insulation - entire cabinet structure and solid doors are foamed-in-place using high density, CFC free, polyurethane insulation.
- Welded, heavy duty galvanized frame rail dipped in rust inhibiting enamel paint for corrosion protection inside and out.
- Frame rail fitted with 4" (102 mm) diameter stem castors - locks provided on front set.

DOORS

- 300 series stainless steel exterior with white aluminum liners to match cabinet interior. Doors extend full width of cabinet shell. Door locks standard.
- Lifetime guaranteed recessed door handles. Each door fitted with 12" (305 mm) long recessed handle that is foamed-in-place with a sheet metal interlock to ensure permanent attachment.
- Positive seal self-closing doors. Lifetime guaranteed door hinges and torsion type closure system.
- Magnetic door gaskets of one piece construction, removable without tools for ease of cleaning.

SHELVING

- Six (6) adjustable, heavy duty PVC coated wire shelves 17½" L x 22¾" D (445 mm x 569 mm). Four (4) chrome plated shelf clips included per shelf.
- Shelf support pilasters made of same material as cabinet interior; shelves are adjustable on ½" (13 mm) increments.

LIGHTING

- Incandescent interior lighting - safety shielded. Lights activated by rocker switch mounted above doors.

MODEL FEATURES

- Exterior temperature display.
- Evaporator is epoxy coated to eliminate the potential of corrosion.
- Rear airflow guards prevent product from blocking optimal airflow.
- NSF-7 compliant for open food product.

ELECTRICAL

- Unit completely pre-wired at factory and ready for final connection to a 115/60/1 phase - 20 amp dedicated outlet. Cord and plug set included.



115/60/1
NEMA-5-20R

OPTIONAL FEATURES/ACCESSORIES

Upcharge and lead times may apply.

- 230 - 240V / 50 Hz.
- 6" (153 mm) standard legs.
- 6" (153 mm) seismic/flanged legs.
- Additional shelves.
- Half door bun tray racks. Each holds up to eleven 12" L x 20" D (305 mm x 508 mm) sheet pans (sold separately) (airflow guards need to be removed).
- Full door bun tray racks. Each holds up to twenty-two 12" L x 20" D (305 mm x 508 mm) sheet pans (sold separately) (airflow guards need to be removed).
- Remote cabinets (condensing unit supplied by others; system comes standard with 404A expansion valve and requires R404A refrigerant). Consult factory technical service department for BTU information.

PLAN VIEW

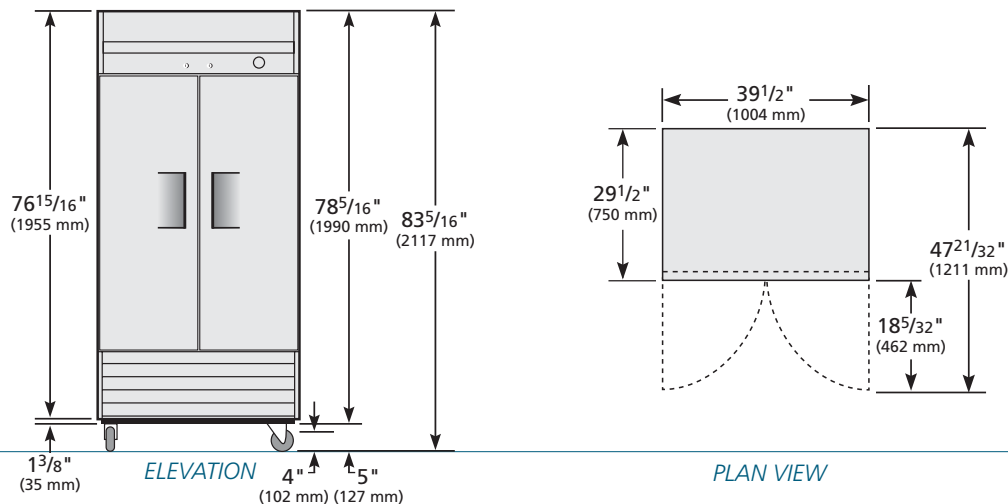

WARRANTY
One year warranty on all parts & labor and an additional 4 year warranty on compressor. (U.S.A. only)

METRIC DIMENSIONS ROUNDED UP TO THE NEAREST WHOLE MILLIMETER
SPECIFICATIONS SUBJECT TO CHANGE WITHOUT NOTICE



Model	Elevation	Right	Plan	3D
T-35F	TFEY04E	TFEY04S	TFEY04P	TFEY043

TRUE FOOD SERVICE EQUIPMENT