



TRUE FOOD SERVICE EQUIPMENT, INC.



Pizzaovens.com

1.877.FOR.OVEN
367.6836

Since 1999

Project Name: _____

Location: _____

Item #: _____ Qty: _____

Model #: _____

AIA #

SIS #

Model:
TR1RPT-1HG/1HS-1S

TR Series:
Pass-Thru Combination Glass/Solid Door Refrigerator



TR1RPT-1HG/1HS-1S

- ▶ Designed using the highest quality materials and components to provide the user with colder product temperatures, lower utility costs and exceptional food safety.
- ▶ Oversized, factory balanced, refrigeration system holds 33°F to 38°F (.5°C to 3.3°C) for the best in food preservation.
- ▶ 300 series stainless steel exterior and interior. The very finest stainless with higher tensile strength for fewer dents and scratches.
- ▶ 300 series stainless steel solid doors. Energy efficient "Low-E", double pane thermal glass door assembly with extruded aluminum frame.
- ▶ Glass door features patented, integrated door light (IDL) system.
- ▶ Equipped with (1) interior kit option, factory installed. Four (4) different interior kits available.
- ▶ Positive seal self-closing doors with 120° stay open feature. Lifetime guaranteed door hinges.
- ▶ Entire cabinet structure and solid doors are foamed-in-place using high density, CFC free, polyurethane insulation.

ROUGH-IN DATA

Specifications subject to change without notice.
Chart dimensions rounded up to the nearest 1/8" (millimeters rounded up to next whole number).

Model	Doors	Capacity (Cu. Ft.) (liters)	Cabinet Dimensions (inches) (mm)			HP	Voltage	Amps	NEMA Config.	Cord Length (total ft.) (total m)	Crated Weight (lbs.) (kg)
			L	D [†]	H [*]						
TR1RPT-1HG/1HS-1S	3	31 878	29 737	37 ¹ / ₂ 953	78 ¹ / ₄ 1988	1/2	115/60/1	10.4	5-15P	9 2.74	N/A

[†] Depth does not include 1³/₈" (35 mm) for glass door handle.

^{*} Height does not include 5" (127 mm) for castors or 6" (153 mm) for optional legs, and 1" (26 mm) for system mechanical components.

7/07 Printed in U.S.A.

APPROVALS:

AVAILABLE AT:

Model:

TR1RPT-1HG/1HS-1S

TR Series:

Pass-Thru Combination Glass/Solid Door Refrigerator



STANDARD FEATURES

DESIGN

- True's combination door pass-thru's are designed with enduring quality that protects your long term investment.
- Designed using the highest quality materials and components to provide the user with colder product temperatures, lower utility costs and exceptional food safety.

REFRIGERATION SYSTEM

- Factory engineered, self-contained, capillary tube system using environmentally friendly (CFC free) 134A refrigerant.
- Extra large evaporator coil balanced with higher horsepower compressor and large condenser maintains cabinet temperatures of 33°F to 38°F (5°C to 3.3°C) for the best in food preservation.
- Sealed, cast iron, self-lubricating evaporator fan motor(s) and larger fan blades give True pass-thru's a more efficient low velocity, high volume airflow design. This unique design ensures faster temperature recovery and shorter run times in the busiest of foodservice environments.
- Top mounted refrigeration system with evaporator positioned out of food zone to maximize capacity.
- Hot gas condensate for energy efficiency.

CABINET CONSTRUCTION

- Exterior - 300 series stainless steel front, sides, rear and bottom.
- Interior - 300 series stainless steel liner and floor with coved corners.
- Insulation - entire cabinet structure is foamed-in-place using high density, CFC free, polyurethane insulation.
- Welded, heavy duty galvanized frame rail dipped in rust inhibiting enamel paint for corrosion protection inside and out.
- Frame rail fitted with 4" (102 mm) diameter stem castors - locks provided on front set.

DOORS

- Solid doors - 300 series stainless steel exterior and liner to match cabinet interior.
Glass half door - "Low-E", double pane thermal insulated glass assembly with extruded aluminum frame. Doors open within cabinet dimension.
- Door locks standard.
- Solid doors fitted with 12" (305 mm) long, lifetime guaranteed recessed handles.
Glass door fitted with 15" (381 mm) long extruded aluminum handle.
- Positive seal self-closing doors with 120° stay open feature. Lifetime guaranteed door hinges.
- Magnetic door gaskets of one piece construction, removable without tools for ease of cleaning.

SHELVING

- One (1) factory installed, interior kit option. Four (4) different interior kits available (see Kit Options). Pilasters and tray slides are factory installed at no charge.

LIGHTING

- Fluorescent interior lighting. Glass door utilizes full-length, patented, integrated door light (IDL) system. Safety shielded.

MODEL FEATURES

- Exterior digital temperature display, available with either °F or °C.
- Evaporator epoxy coated to eliminate the potential of corrosion.
- NSF-7 compliant for open food product.

ELECTRICAL

- Unit completely pre-wired at factory and ready for final connection to a 115/60/1 phase, 15 amp dedicated outlet. Cord and plug set included.



115/60/1
NEMA-5-15R

OPTIONAL FEATURES/ACCESSORIES

Upcharge and lead times may apply.

- 6" (153 mm) standard legs.
- 6" (153 mm) seismic/flanged legs.
- 6" (153 mm) stainless steel legs.
- Stainless steel rail skirt for use with legs (field installed).
- Metal door handles (factory installed).
- Electronic temperature control (factory installed).
- Curb mountable units.
- Remote cabinets (condensing unit supplied by others; system comes standard with 404A expansion valve and requires R404A refrigerant). Consult factory technical service department for BTU information.

KIT OPTIONS

- Kit #1: Nine (9) sets of #1 type tray slides and pilasters (factory installed), bottom support of one (1) 18" L x 26" D (458 mm x 661 mm) pan or two (2) 14" L x 18" D (356 mm x 458 mm) pans.
- Kit #2: One (1) set half-section #2 steel rod tray slides and pilasters (factory installed), rim support of one (1) 18" L x 26" D (458 mm x 661 mm) pan.
- Kit #3: Six (6) sets of universal type tray slides and pilasters (factory installed), bottom support of one (1) 18" L x 26" D (458 mm x 661 mm) pan, two (2) 14" L x 18" D (356 mm x 458 mm) pans or two (2) 12" L x 20" D (305 mm x 508 mm) pans.
- Kit #4: Three (3) chrome shelves 25" L x 28¹³/₁₆" D (635 mm x 732 mm). Four (4) shelf supports included per shelf (factory installed); adjustable on 6" (153 mm) increments. Optional wall mounted shelf support pilasters (factory installed) with four (4) shelf clips per shelf available; adjustable on 1/2" (13 mm) increments.
- Additional kit option components available individually. Upcharge applies.

PLAN VIEW

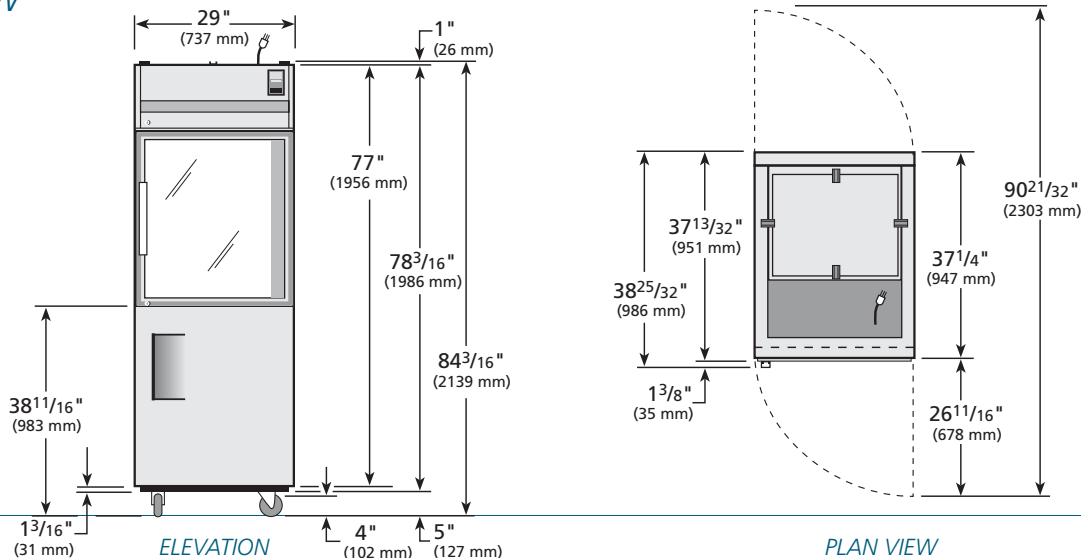

WARRANTY

One year warranty on all parts and labor and an additional 4 year warranty on compressor. (U.S.A. only)

METRIC DIMENSIONS ROUNDED UP TO THE NEAREST WHOLE MILLIMETER

SPECIFICATIONS SUBJECT TO CHANGE WITHOUT NOTICE



Model	Elevation	Right	Plan	3D
TR1RPT-1HG/1HS-1S	TFQX68E	TFT006S	TFT001P	TFT0063

TRUE FOOD SERVICE EQUIPMENT