



**TRUE FOOD SERVICE
EQUIPMENT, INC.**



Pizzaovens.com

1.877.FOR.OVEN
367.6836

Since 1999

Project Name: _____

Location: _____

Item #: _____ Qty: _____

Model #: _____

A/A #

SIS #

Model:
TR2R-2HG/2HS

TR Series:
Reach-In Combination Half Glass / Half Solid Door Refrigerator



TR2R-2HG/2HS

- ▶ Designed using the highest quality materials and components to provide the user with colder product temperatures, lower utility costs and exceptional food safety.
- ▶ Oversized, factory balanced, refrigeration system holds 33°F to 38°F (.5°C to 3.3°C) for the best in food preservation.
- ▶ 300 series stainless steel exterior and interior. The very finest stainless with higher tensile strength for fewer dents and scratches.
- ▶ 300 series stainless steel solid doors. Energy efficient "Low-E", double pane thermal glass door assemblies with extruded aluminum frames.
- ▶ Patented integrated door light (IDL) system.
- ▶ Equipped with one (1) interior kit option per full section standard, factory installed. Four (4) different interior kits available.
- ▶ Positive seal self-closing doors with 120° stay open feature. Lifetime guaranteed door hinges.
- ▶ Entire cabinet structure and solid doors are foamed-in-place using high density, CFC free, polyurethane insulation.

ROUGH-IN DATA

Specifications subject to change without notice.
Chart dimensions rounded up to the nearest 1/8" (millimeters rounded up to next whole number).

Model	Doors	Capacity (Cu. Ft.) (liters)	Cabinet Dimensions (inches) (mm)			HP	Voltage	Amps	NEMA Config.	Cord Length (total ft.) (total m)	Crated Weight (lbs.) (kg)
			L	D [†]	H [*]						
TR2R-2HG/2HS	4	56 1586	51 ³ / ₈ 1305	34 ⁷ / ₈ 886	78 ¹ / ₄ 1988	1/2	115/60/1	10.0	5-15P	9 2.74	640 291

[†] Depth does not include 1³/₈" (35 mm) for glass door handles.

^{*} Height does not include 5" (127 mm) for castors or 6" (153 mm) for optional legs, and 1" (26 mm) for system mechanical components.



APPROVALS:

AVAILABLE AT:

Model:

TR2R-2HG/2HS

TR Series:

*Reach-In Combination Half Glass /
Half Solid Door Refrigerator*



STANDARD FEATURES

DESIGN

- True's combination door reach-in's are designed with enduring quality that protects your long term investment.
- Designed using the highest quality materials and components to provide the user with colder product temperatures, lower utility costs and exceptional food safety.

REFRIGERATION SYSTEM

- Factory engineered, self-contained, capillary tube system using environmentally friendly (CFC free) 134A refrigerant.
- Extra large evaporator coil balanced with higher horsepower compressor and large condenser maintains cabinet temperatures of 33°F to 38°F (5°C to 3.3°C) for the best in food preservation.
- Sealed, cast iron, self-lubricating evaporator fan motor(s) and larger fan blades give True reach-in's a more efficient low velocity, high volume airflow design. This unique design ensures faster temperature recovery and shorter run times in the busiest of food service environments.
- Top mounted refrigeration system with evaporator positioned out of food zone to maximize capacity.
- Hot gas condensate for energy efficiency.
- Glass condensate pan to prevent electrolysis.

CABINET CONSTRUCTION

- Exterior - 300 series stainless steel solid doors, front, sides, back and bottom.
- Interior - 300 series stainless steel liner and floor.
- Insulation - entire cabinet structure and solid doors are foamed-in-place using high density, CFC free, polyurethane insulation.
- Welded, heavy duty galvanized frame rail dipped in rust inhibiting enamel paint for corrosion protection inside and out.
- Frame rail fitted with 4" (102 mm) diameter stem castors - locks provided on front set.

DOORS

- Solid half doors - 300 series stainless steel exterior and interior. Glass half doors - "Low-E", double pane thermal glass assemblies with extruded aluminum frames.
- Door locks standard.
- Each solid door fitted with 12" (305 mm) long, lifetime guaranteed recessed handle. Each glass door fitted with a 15" (381 mm) long extruded aluminum handle.
- Positive seal self-closing doors with 120° stay open feature. Lifetime guaranteed door hinges.
- Magnetic door gaskets of one piece construction, removable without tools for ease of cleaning.

SHELVING

- One (1) factory installed interior kit option per full section. Four (4) different interior kits available (see Kit Options). Pilasters and tray slides are factory installed at no charge.

LIGHTING

- Fluorescent interior lighting. Each glass half door utilizes full-length, patented, integrated door light (IDL) system. Safety shielded.

MODEL FEATURES

- Exterior digital temperature display, available with either °F or °C.
- Evaporator is epoxy coated to eliminate the potential of corrosion.
- NSF-7 compliant for open food product.

ELECTRICAL

- Unit completely pre-wired at factory and ready for final connection to a 115/60/1 phase - 15 amp dedicated outlet. Cord and plug set included.



115/60/1
NEMA-5-15R

OPTIONAL FEATURES/ACCESSORIES

Upcharge and lead times may apply.

- 6" (153 mm) standard legs.
- 6" (153 mm) seismic/flanged legs.
- 6" (153 mm) stainless steel legs.
- Stainless steel rail skirt for use with legs (field installed).
- Solid door metal door handle (factory installed).
- Electronic temperature control (factory installed).
- Curb mountable units.
- Remote cabinets (condensing unit supplied by others; system comes standard with 404A expansion valve and requires R404A refrigerant). Consult factory technical service department for BTU information.

KIT OPTIONS

- Kit #1: Nine (9) sets of #1 type tray slides and pilasters (factory installed), bottom support of one (1) 18"L x 26"D (458 mm x 661 mm) pan or two (2) 14"L x 18"D (356 mm x 458 mm) pans.
- Kit #2: One (1) set half-section #2 steel rod tray slides and pilasters (factory installed), rim support of one (1) 18"L x 26"D (458 mm x 661 mm) pan.
- Kit #3: Six (6) sets of universal type tray slides and pilasters (factory installed), bottom support of one (1) 18"L x 26"D (458 mm x 661 mm) pan, two (2) 14"L x 18"D (356 mm x 458 mm) pans or two (2) 12"L x 20"D (305 mm x 508 mm) pans.
- Kit #4: Three (3) chrome shelves 23 1/2"L x 27 3/4"D (597 mm x 705 mm). Four (4) shelf supports included per shelf (factory installed). Shelves adjustable on 6" (153 mm) increments.
- Additional kit option components available individually.

PLAN VIEW

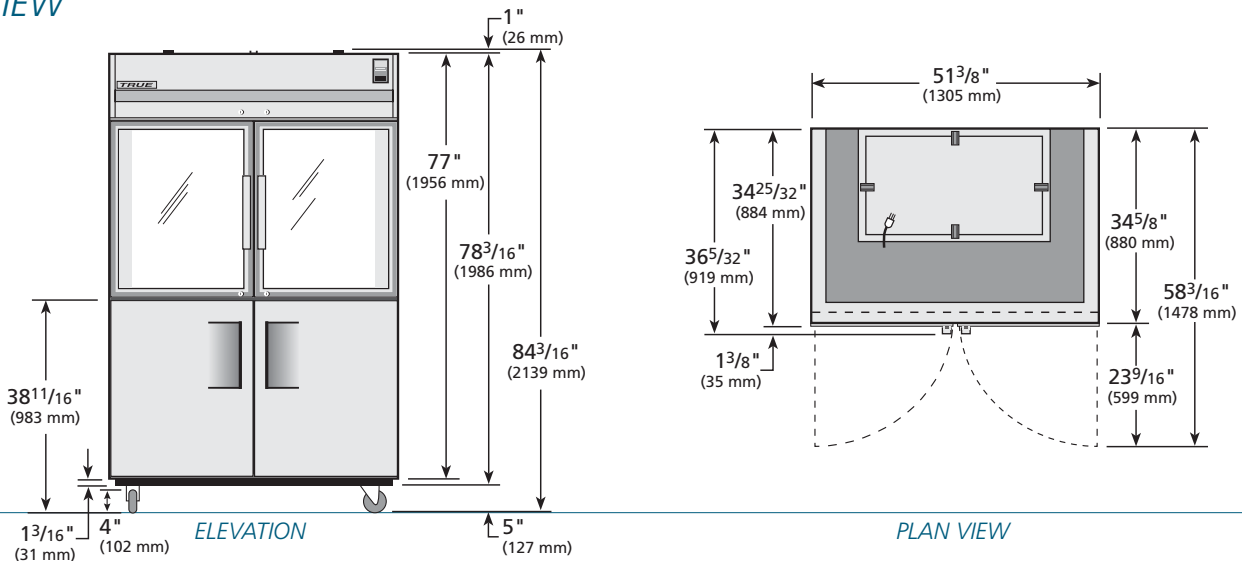

WARRANTY

One year warranty on all parts and labor and an additional 4 year warranty on compressor. (U.S.A. only)

METRIC DIMENSIONS ROUNDED UP TO THE NEAREST WHOLE MILLIMETER

SPECIFICATIONS SUBJECT TO CHANGE WITHOUT NOTICE



Model	Elevation	Right	Plan	3D
TR2R-2HG/2HS	TFQX57E	TFQX57S	TFQY99P	TFQX573