



**TRUE FOOD SERVICE
EQUIPMENT, INC.**



Pizzaovens.com

1.877.FOR.OVEN
367.6836
Since 1999

Project Name: _____

Location: _____

Item #: _____ Qty: _____

Model #: _____

A/A #

SIS #

Model:
TS-23-2

TS Series:
Reach-In 300 Series Stainless Steel Solid Half Door Refrigerator



TS-23-2

- ▶ True's TS series is the choice for the exclusive 300 series stainless steel commercial application.
 - ▶ Designed using the highest quality materials and components to provide the user with colder product temperatures, lower utility costs, exceptional food safety and the best value in today's food service marketplace.
 - ▶ Oversized, factory balanced, refrigeration system holds 33°F to 38°F (.5°C to 3.3°C) for the best in food preservation.
 - ▶ 300 series stainless steel interior and exterior front, sides and doors. The very finest stainless with higher tensile strength for fewer dents and scratches. Matching aluminum back.
 - ▶ Adjustable, heavy duty PVC coated shelves.
 - ▶ Positive seal self-closing doors. Lifetime guaranteed door hinges and torsion type closure system.
- Bottom mounted units feature:**
- ▶ "No stoop" lower shelf.
 - ▶ Storage on top of cabinet.
 - ▶ Compressor performs in coolest, most grease free area of kitchen.
 - ▶ Easily accessible condenser coil for cleaning.

ROUGH-IN DATA

Specifications subject to change without notice.
Chart dimensions rounded up to the nearest 1/8" (millimeters rounded up to next whole number).

Model	Doors	Capacity (Cu. Ft.) (liters)	Shelves	Cabinet Dimensions (inches) (mm)			HP	Voltage	Amps	NEMA Config.	Cord Length (total ft.) (total m)	Crated Weight (lbs.) (kg)
				L	D	H*						
TS-23-2	2	23 652	3	27 686	29 1/2 750	78 3/8 1991	1/3 1/3	115/60/1 230-240/50/1	7.5 4.0	5-15P ▲	9 2.74	305 139

* Height does not include 5" (127 mm) for castors or 6" (153 mm) for optional legs.

▲ Plug type varies by country.

3/08 Printed in U.S.A.

APPROVALS:

AVAILABLE AT:

Model:
TS-23-2

TS Series:
Reach-In 300 Series Stainless Steel
Solid Half Door Refrigerator



STANDARD FEATURES

DESIGN

- True's solid door reach-in's are designed with enduring quality that protects your long term investment.
- True's commitment to using the highest quality materials and oversized refrigeration systems provides the user with colder product temperatures, lower utility costs, exceptional food safety and the best value in today's food service marketplace.

REFRIGERATION SYSTEM

- Factory engineered, self-contained, capillary tube system using environmentally friendly (CFC free) 134A refrigerant.
- Extra large evaporator coil balanced with higher horsepower compressor and large condenser maintains 33°F to 38°F (.5°C to 3.3°C) for the best in food preservation.
- Sealed, cast iron, self-lubricating evaporator fan motor(s) and larger fan blades give True reach-in's a more efficient, low velocity, high volume airflow design. This unique design ensures faster temperature recovery and shorter run times in the busiest of food service environments.
- Bottom mounted condensing unit positioned for easy maintenance. Compressor runs in coolest and most grease free area of the kitchen. Allows for storage area on top of unit.

CABINET CONSTRUCTION

- Exterior - 300 series stainless steel doors, front, and sides. Matching aluminum back.

- Interior - 300 series stainless steel liner and floor.
- Insulation - entire cabinet structure and solid doors are foamed-in-place using high density, CFC free, polyurethane insulation.
- Welded, heavy duty galvanized frame rail dipped in rust inhibiting enamel paint for corrosion protection inside and out.
- Frame rail fitted with 4" (102 mm) diameter stem castors standard - locks provided on front set.

DOORS

- 300 series stainless steel exterior and liners. Doors extend full width of cabinet shell. Door lock standard.
- Positive seal self-closing doors. Lifetime guaranteed door hinges and torsion type closure system.
- Lifetime guaranteed recessed door handles. Each door fitted with 12" (305 mm) long recessed handle that is foamed-in-place with a sheet metal interlock to ensure permanent attachment.
- Magnetic door gaskets of one piece construction, removable without tools for ease of cleaning.

SHELVING

- Three (3) adjustable, heavy duty PVC coated wire shelves 22⁷/₈" L x 23¹/₄" D (582 mm x 591 mm). Four (4) chrome plated shelf clips included per shelf.
- Aluminum shelf support pilasters. Shelves are adjustable on 1/2" (13 mm) increments.

LIGHTING

- Incandescent interior lighting - safety shielded. Lights activated by rocker switch mounted above top door.

MODEL FEATURES

- Evaporator is epoxy coated to eliminate the potential of corrosion.
- Exterior solar, digital temperature display.
- NSF-7 compliant for open food product.

ELECTRICAL

- Unit completely pre-wired at factory and ready for final connection to a 115/60/1 phase - 15 amp dedicated outlet. Cord and plug set included.



115/60/1
NEMA-5-15R

OPTIONAL FEATURES/ACCESSORIES

Upcharge and lead time may apply.

- 230 - 240V/50 Hz.
- 6" (153 mm) standard legs.
- 6" (153 mm) seismic/flanged legs.
- Alternate door hinging (factory installed).
- Additional shelves.
- Half bun tray rack holds up to eleven 18" L x 26" D (458 mm x 661 mm) sheet pans (sold separately).
- Remote cabinets (condensing unit supplied by others; system comes standard with 404A expansion valve and requires R404A refrigerant). Consult factory technical service department for BTU information.

PLAN VIEW

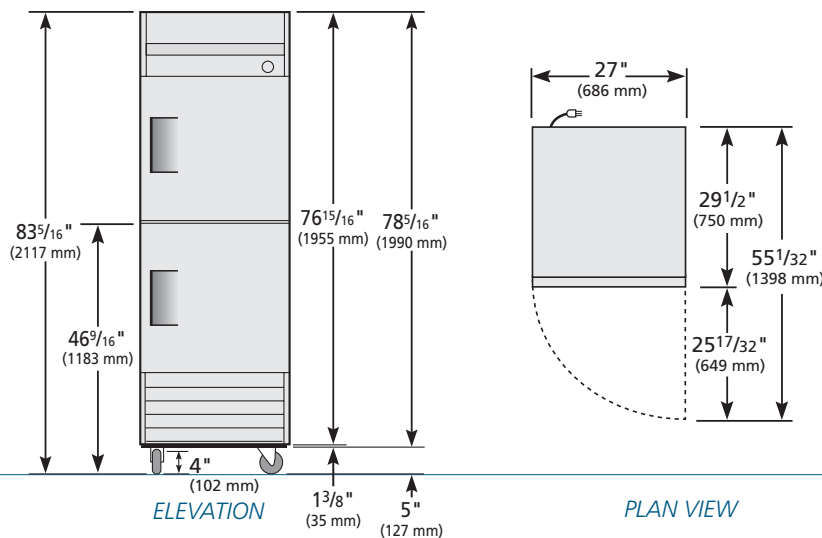

WARRANTY

One year warranty on all parts and labor and an additional 4 year warranty on compressor. (U.S.A. only)

METRIC DIMENSIONS ROUNDED UP TO THE NEAREST WHOLE MILLIMETER
SPECIFICATIONS SUBJECT TO CHANGE WITHOUT NOTICE



Model	Elevation	Right	Plan	3D
TS-23-2	TFGY07E	TFGY07S	TFEY03P	TFGY073

TRUE FOOD SERVICE EQUIPMENT