



TRUE FOOD SERVICE EQUIPMENT, INC.



Pizzaovens.com

1.877.FOR.OVEN
367.6836
Since 1999

Project Name: _____

Location: _____

Item #: _____ Qty: _____

Model #: _____

AIA #

SIS #

Model:
TS-23F-2

TS Series:
Reach-In All Stainless Steel Solid Half Door Freezer



TS-23F-2

- ▶ Designed using the highest quality materials and components to provide the user with colder product temperatures, lower utility costs, exceptional food safety and the best value in today's food service marketplace.
 - ▶ Extra large evaporator coil balanced with higher horsepower compressor and large condenser; maintains -10°F (-23.3°C) cabinet temperatures. Ideally suited for both frozen food and ice cream.
 - ▶ 300 series stainless steel solid doors, front and sides. The finest stainless available; higher tensile strength for fewer dents and scratches.
 - ▶ Adjustable, heavy duty PVC coated shelves.
 - ▶ Positive seal self-closing doors. Lifetime guaranteed door hinges and torsion type closure system.
 - ▶ Automatic defrost system time-initiated temperature-terminated. Saves energy consumption and provides shortest possible defrost cycle.
- Bottom mounted units feature:**
- ▶ "No stoop" lower shelf.
 - ▶ Storage on top of cabinet.
 - ▶ Compressor performs in coolest, most grease free area of kitchen.
 - ▶ Easily accessible condenser coil for cleaning.

ROUGH-IN DATA

Specifications subject to change without notice.
Chart dimensions rounded up to the nearest 1/8" (millimeters rounded up to next whole number).

Model	Solid Doors	Capacity (Cu. Ft.) (liters)	# of Shelves	Cabinet Dimensions (inches) (mm)			HP	Voltage	Amps	NEMA Config.	Cord Length (total ft.) (total m)	Crated Weight (lbs.) (kg)
				L	D	H*						
TS-23F-2	2	23	3	27	29 1/2	78 3/8	1/2	115/60/1	10.4	5-15P	9	330
		652		686	750	1991	N/A	230-240/50/1	N/A	▲	2.74	150

* Height does not include 5" (127 mm) for castors or 6" (153 mm) for optional legs.

▲ Plug type varies by country.



APPROVALS:

Model:
TS-23F-2

TS Series:
Reach-In All Stainless Steel Solid Half Door Freezer



STANDARD FEATURES

DESIGN

- True's solid door reach-in's are designed with enduring quality that protects your long term investment.
- True's commitment to using the highest quality materials and oversized refrigeration systems provides the user with colder product temperatures, lower utility costs, exceptional food safety and the best value in today's food service marketplace.

REFRIGERATION SYSTEM

- Factory engineered, self-contained, capillary tube system using environmentally friendly (CFC free) R404A refrigerant.
- Extra large evaporator coil balanced with higher horsepower compressor and large condenser maintains -10°F (-23.3°C). Ideal for both frozen food and ice cream.
- Sealed, cast iron, self-lubricating evaporator fan motor and larger fan blades give True reach-in's a more efficient, low velocity, high volume airflow design. This unique design insures faster temperature recovery and shorter run times in the busiest of food service environments.
- Bottom mounted condensing unit positioned for easy maintenance. Compressor runs in coolest and most grease free area of the kitchen. Allows for storage area on top of unit.
- Automatic defrost system time-initiated, temperature terminated. Saves energy consumption and provides shortest defrost cycle.

CABINET CONSTRUCTION

- Exterior - 300 series stainless steel doors, front, and sides. Matching aluminum back.
- Interior - 300 series stainless steel liner and floor.
- Insulation - entire cabinet structure and solid doors are foamed-in-place using high density, CFC free, polyurethane insulation.
- Cabinet mounted on a welded, heavy duty galvanized frame rail. Rail dipped in rust inhibiting enamel paint for corrosion protection inside and out.
- Frame rail fitted with 4" (102 mm) diameter stem castors - locks provided on front set.

DOORS

- 300 series stainless steel exterior and door liner. Doors extend full width of cabinet shell. Door lock standard.
- Positive seal self-closing doors. Lifetime guaranteed door hinges and torsion type closure system.
- Lifetime guaranteed recessed door handles. Each door fitted with 12" (305 mm) long recessed handle that is foamed-in-place with a sheet metal interlock to insure permanent attachment.
- Magnetic door gaskets of one piece construction, removable without tools for ease of cleaning.

SHELVING

- Three (3) adjustable, heavy duty PVC coated wire shelves 227/8"L x 231/4"D (582 mm x 591 mm). Four (4) chrome plated shelf clips included per shelf.

- Shelf support pilasters made of same material as cabinet interior; shelves are adjustable on 1/2" (13 mm) increments.

LIGHTING

- Incandescent interior lighting - safety shielded. Lights activated by rocker switch mounted above top door.

MODEL FEATURES

- Evaporator is epoxy coated to eliminate the potential of corrosion.
- Exterior mounted temperature monitor.
- NSF-7 compliant for open food product.

ELECTRICAL

- Unit completely pre-wired at factory and ready for final connection to a 115/60/1 phase - 15 amp dedicated outlet. Cord and plug set included.



115/60/1
NEMA-5-15R

OPTIONAL FEATURES/ACCESSORIES

Upcharge and lead time may apply.

- 230 - 240V/50 Hz.
- 6" (153 mm) standard legs.
- 6" (153 mm) seismic/flanged legs.
- Additional shelves.
- Half door bun tray racks. Holds up to eleven 18" L x 26" D (458 mm x 661 mm) sheet pans (sold separately) (airflow guards need to be removed).
- Remote cabinets (condensing unit supplied by others), consult factory technical service department for BTU information.

PLAN VIEW

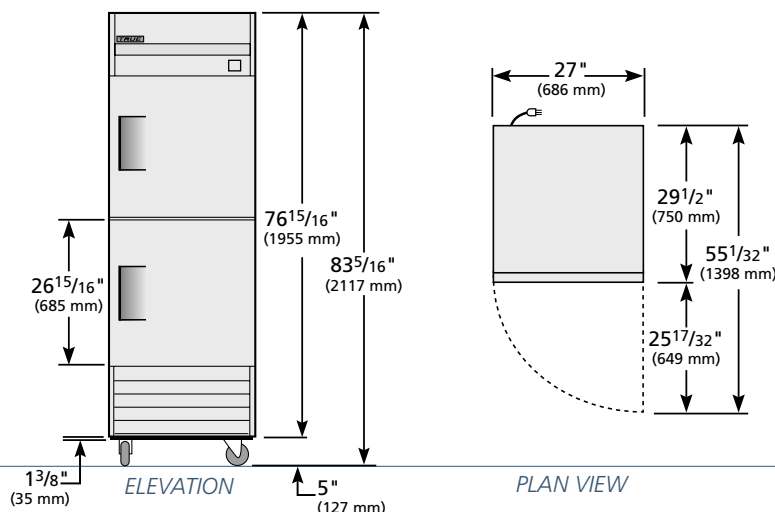

WARRANTY

One year warranty on all parts & labor and an additional 4 year warranty on compressor. (U.S.A. only)

METRIC DIMENSIONS ROUNDED UP TO THE NEAREST WHOLE MILLIMETER

SPECIFICATIONS SUBJECT TO CHANGE WITHOUT NOTICE



Model	Elevation	Right	Plan	3D
TS-23F-2	TFGY07E	TFGY07S	TFEY03P	TFGY073

TRUE FOOD SERVICE EQUIPMENT