



**TRUE FOOD SERVICE  
EQUIPMENT, INC.**



Pizzaovens.com

1.877.FOR.OVEN  
367.6836

Since 1999

Project Name: \_\_\_\_\_

Location: \_\_\_\_\_

Item #: \_\_\_\_\_ Qty: \_\_\_\_\_

Model #: \_\_\_\_\_

A/A #

SIS #

Model:  
**TUC-119**

**Deep Undercounter:**  
*Solid Door Refrigerator*

## TUC-119

- ▶ True's deep undercounter units feature the combined advantage of undercounter placement with deeper refrigerated storage.
- ▶ Designed using the highest quality materials and components to provide the user with colder product temperatures, lower utility costs, exceptional food safety and the best value in today's food service marketplace.
- ▶ Oversized, environmentally friendly (134A) forced-air refrigeration system holds 33°F to 38°F (.5°C to 3.3°C).
- ▶ All stainless steel front, top and ends. Matching aluminum finished back.
- ▶ NSF approved, white aluminum interior liner. 300 series stainless floor with coved corners.
- ▶ Heavy duty PVC coated wire shelves.
- ▶ Foamed-in-place, high density polyurethane insulation (CFC free).



## ROUGH-IN DATA

Specifications subject to change without notice.  
Chart dimensions rounded up to the nearest 1/8" (millimeters rounded up to next whole number).

Model	Doors	Capacity (Cu. Ft.) (liters)	Shelves	Cabinet Dimensions (inches) (mm)			HP	Voltage	Amps	NEMA Config.	Cord Length (total ft.) (total m)	Crated Weight (lbs.) (kg)
				L	D†	H*						
TUC-119	4	43.9 1244	8	119 <sup>1</sup> / <sub>4</sub> 3029	32 <sup>1</sup> / <sub>4</sub> 820	29 <sup>3</sup> / <sub>4</sub> 756	1/2 1/2	115/60/1 230-240V/50/1	12.0 5.2	5-15P ▲	7 2.13	660 300

† Depth does not include 1" (26 mm) for rear bumpers and 1/4" (7 mm) for front bumper.

▲ Plug type varies by country.

\* Height does not include 6 1/4" (159 mm) for castors or 6" (153 mm) for optional legs.



APPROVALS:

AVAILABLE AT:

Model:  
**TUC-119**

**Deep Undercounter:**  
Solid Door Refrigerator



**STANDARD FEATURES**

**DESIGN**

- True's deep undercounter units are designed with enduring quality that protects your long term investment.
- True's commitment to using the highest quality materials and oversized refrigeration systems provides the user with colder product temperatures, lower utility costs, exceptional food safety and the best value in today's food service marketplace.

**REFRIGERATION SYSTEM**

- Factory engineered, self-contained, capillary tube system using environmentally friendly (CFC free) 134A refrigerant.
- Oversized, factory balanced refrigeration system with guided airflow to provide uniform product temperatures.
- Extra large evaporator coil balanced with higher horsepower compressor and large condenser; maintains cabinet temperatures of 33°F to 38°F (.5°C to 3.3°C) for the best in food preservation.
- Sealed, cast iron, self-lubricating evaporator fan motor(s) and larger fan blades give True undercounter units a more efficient, low velocity, high volume airflow design. This unique design ensures faster temperature recovery and shorter run times in the busiest of food service environments.
- Condensing unit is accessed from behind front grill; slides out for easy maintenance.

**CABINET CONSTRUCTION**

- Exterior - stainless steel front, top and ends. Matching aluminum finished back.
- Interior - attractive, NSF approved, white aluminum liner. 300 series stainless steel floor with coved corners.
- Insulation - entire cabinet structure and solid door(s) are foamed-in-place using high density, CFC free, polyurethane insulation.
- 5" (127 mm) diameter stem castors - locks provided on front set. 36" (915 mm) work surface height.

**DOORS**

- Stainless steel exterior with white aluminum liner to match cabinet interior.
- Each door fitted with 12" (305 mm) long recessed handle that is foamed-in-place with a sheet metal interlock to ensure permanent attachment.
- Positive seal doors swing within cabinet dimensions.
- Magnetic door gasket(s) of one piece construction, removable without tools for ease of cleaning.

**SHELVING**

- Eight (6) adjustable, heavy duty PVC coated wire shelves. Right and left door shelf dimensions are 23<sup>5</sup>/<sub>8</sub>" L x 28" D (601 mm x 712 mm). Two (2) center door shelf dimensions are 25<sup>1</sup>/<sub>2</sub>" L x 28" D (648 mm x 712 mm). Four (4) chrome plated shelf clips included per shelf.
- Shelf support pilasters made of same material as cabinet interior; shelves are adjustable on 1/2" (13 mm) increments.

**MODEL FEATURES**

- Evaporator is epoxy coated to eliminate the potential of corrosion.

**ELECTRICAL**

- Unit completely pre-wired at factory and ready for final connection to a 115/60/1 phase, 15 amp dedicated outlet. Cord and plug set included.



115/60/1  
NEMA-5-15R

**OPTIONAL FEATURES/ACCESSORIES**

Upcharge and lead times may apply.

- 230 - 240V/50 Hz.
- 6" (153 mm) standard legs.
- 6" (153 mm) seismic/flanged legs.
- 2<sup>1</sup>/<sub>2</sub>" (64 mm) diameter castors.
- 3" (85 mm) diameter castors.
- Single utility shelf.
- Double utility shelf.
- Half bun tray rack. Each holds up to eleven 18" L x 26" D (458 mm x 661 mm) sheet pans (sold separately).
- Exterior round digital temperature display (factory installed).
- Remote cabinets (condensing unit supplied by others; system comes standard with 404A expansion valve and requires R404A refrigerant). Consult factory technical service department for BTU information.

**PLAN VIEW**

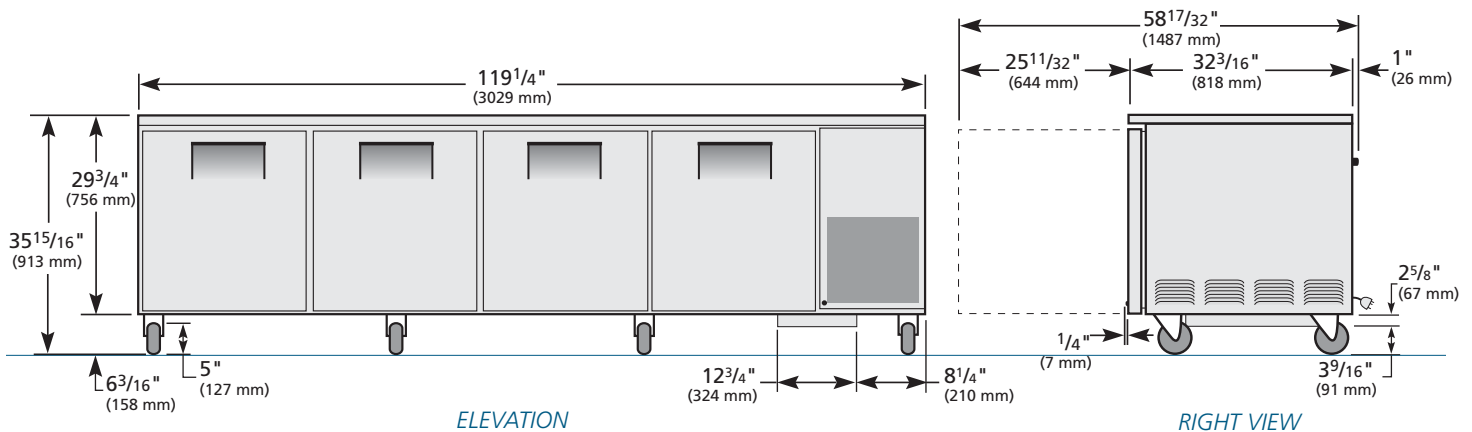

**WARRANTY**  
One year warranty on all parts and labor and an additional 4 year warranty on compressor. (U.S.A. only)

METRIC DIMENSIONS ROUNDED UP TO THE NEAREST WHOLE MILLIMETER  
SPECIFICATIONS SUBJECT TO CHANGE WITHOUT NOTICE



Model	Elevation	Right	Plan	3D
TUC-119	TFQY63E	TFQY63S	TFQY63P	TFQY633