



**TRUE FOOD SERVICE  
EQUIPMENT, INC.**



Pizzaovens.com

1.877.FOR.OVEN  
367.6836

Since 1999

Project Name: \_\_\_\_\_

Location: \_\_\_\_\_

Item #: \_\_\_\_\_ Qty: \_\_\_\_\_

Model #: \_\_\_\_\_

A/A #

SIS #

Model:  
**TUC-27G**

**Undercounter:**  
*Glass Door Refrigerator*

## TUC-27G



- ▶ True's undercounter units are designed with enduring quality that protects your long term investment.
- ▶ Designed using the highest quality materials and components to provide the user with colder product temperatures, lower utility costs, exceptional food safety and the best value in today's food service marketplace.
- ▶ Oversized, environmentally friendly (134A) forced-air refrigeration system holds 33°F to 38°F (.5°C to 3.3°C).
- ▶ All stainless steel, top and cabinet ends. Matching aluminum finished back.
- ▶ Front breathing.
- ▶ Energy efficient, "Low-E", double pane thermal glass door.
- ▶ Foamed-in-place, high density polyurethane insulation (CFC free).
- ▶ Heavy duty PVC coated wire shelves.

## ROUGH-IN DATA

Specifications subject to change without notice.  
Chart dimensions rounded up to the nearest 1/8" (millimeters rounded up to next whole number).

Model	Doors	Capacity (Cu. Ft.) (liters)	Shelves	Cabinet Dimensions (inches) (mm)			HP	Voltage	Amps	NEMA Config.	Cord Length (total ft.) (total m)	Crated Weight (lbs.) (kg)
				L	D†	H*						
TUC-27G	1	6.5 185	2	27 <sup>5</sup> / <sub>8</sub>	30 <sup>1</sup> / <sub>8</sub>	29 <sup>3</sup> / <sub>4</sub>	1/6	115/60/1	3.9	5-15P ▲	7 2.13	210 96
				702	766	756	1/4	230-240/50/1	2.9			

† Depth does not include 1" (26 mm) for rear bumpers or 1/8" (4 mm) for door handle.

▲ Plug type varies by country.

\* Height does not include 6 1/4" (159 mm) for castors or 6" (153 mm) for optional legs.



APPROVALS:

AVAILABLE AT:

10/05

Printed in U.S.A.

Model:  
**TUC-27G**

**Undercounter:**  
Glass Door Refrigerator



## STANDARD FEATURES

### DESIGN

- True's commitment to using the highest quality materials and oversized refrigeration systems provides the user with colder product temperatures, lower utility costs, exceptional food safety and the best value in today's food service marketplace.

### REFRIGERATION SYSTEM

- Factory engineered, self-contained, capillary tube system using environmentally friendly (CFC free) 134A refrigerant.
- Oversized, factory balanced refrigeration system with guided airflow to provide uniform product temperatures.
- Extra large evaporator coil balanced with higher horsepower compressor and large condenser; maintains cabinet temperatures of 33°F to 38°F (.5°C to 3.3°C) for the best in food preservation.
- Sealed, cast iron, self-lubricating evaporator fan motor and larger fan blades give True undercounter units a more efficient low velocity, high volume airflow design. This unique design insures faster temperature recovery and shorter run times in the busiest of food service environments.
- Condensing unit access in back of cabinet, slides out for easy maintenance.

### CABINET CONSTRUCTION

- Exterior - stainless steel, top and cabinet ends. Matching aluminum finished back.

- Interior - attractive, NSF approved, white aluminum liner. 300 series stainless floor with coved corners.
- Insulation - entire cabinet structure is foamed-in-place using high density, CFC free, polyurethane insulation.
- 5" (127 mm) diameter stem castors standard - locks provided on front set. 36" (915 mm) work surface height.

### DOOR

- "Low-E", double pan thermal glass assembly with extruded aluminum frame.
- Door fitted with 15" (381 mm) long extruded aluminum handle.
- Positive seal self-closing door with 90° stay open feature. Door swings within cabinet dimensions.
- Magnetic door gasket of one piece construction, removable without tools for ease of cleaning.

### SHELVING

- Two (2) adjustable, heavy duty PVC coated wire shelves 23<sup>1</sup>/<sub>4</sub>" L x 16" D (591 mm x 407 mm). Four (4) chrome plated shelf clips included per shelf.
- Shelf support pilasters made of same material as cabinet interior; shelves are adjustable on 1/2" (13 mm) increments.

### LIGHTING

- Fluorescent interior lighting.

### MODEL FEATURES

- Evaporator is epoxy coated to eliminate the potential of corrosion.
- NSF-7 compliant for open food product.

### ELECTRICAL

- Unit completely pre-wired at factory and ready for final connection to a 115/60/1 phase - 15 amp dedicated outlet. Cord and plug set included.



115/60/1  
NEMA-5-15R

### OPTIONAL FEATURES/ACCESSORIES

Upcharge and lead times may apply.

- 230 - 240V / 50 Hz.
- 6" (153 mm) standard legs.
- 6" (153 mm) seismic/flanged legs.
- 2<sup>1</sup>/<sub>2</sub>" (64 mm) diameter castors.
- Basic overshelf.
- Single utility shelf.
- Double utility shelf.
- Stacking collar.
- 30" (762 mm) deep, 1/2" (13 mm) thick, white polyethylene cutting board. Requires "L" brackets.
- 30" (762 mm) deep, 1/2" (13 mm) thick, composite cutting board. Requires "L" brackets.
- Heavy duty, 16 gauge tops.
- ADA compliant models with 34" (864 mm) work surface height.
- Low profile models with 31<sup>1</sup>/<sub>2</sub>" (801 mm) work surface height.
- Remote cabinets (condensing units supplied by others; system comes standard with 404A expansion valve and requires R404A refrigerant). Consult factory technical service department for BTU information.

## PLAN VIEW

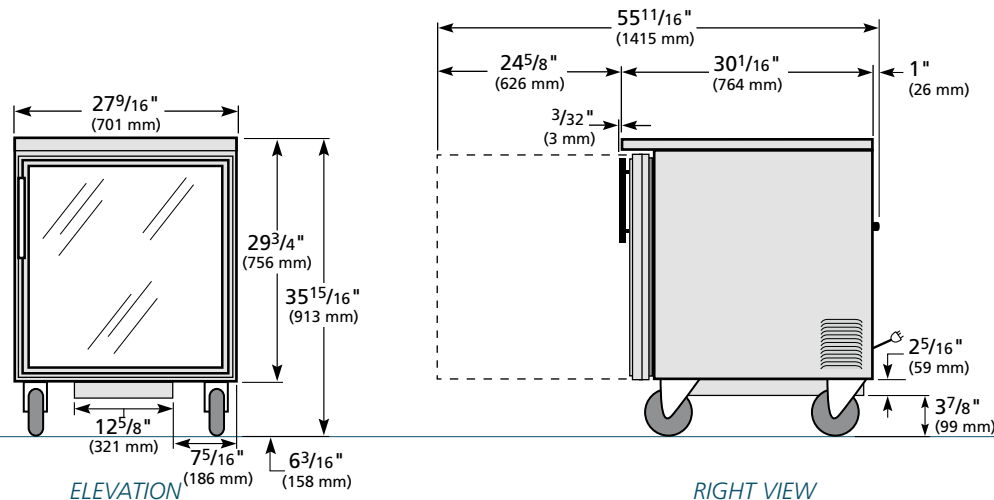

**WARRANTY**  
One year warranty on all parts & labor and an additional 4 year warranty on compressor. (U.S.A. only)

METRIC DIMENSIONS ROUNDED UP TO THE NEAREST WHOLE MILLIMETER  
SPECIFICATIONS SUBJECT TO CHANGE WITHOUT NOTICE



Model	Elevation	Right	Plan	3D
TUC-27G	TFQY04E	TFQY04S	TFQY01P	TFQY043