



TRUE FOOD SERVICE EQUIPMENT, INC.



Pizzaovens.com

1.877.FOR.OVEN
367.6836

Since 1999

Project Name: _____

Location: _____

Item #: _____ Qty: _____

Model #: _____

A/A #

SIS #

Model:
TUC-36-LP

Undercounter:
Low Profile Solid Door Refrigerator



TUC-36-LP

- ▶ Designed using the highest quality materials and components to provide the user with colder product temperatures, lower utility costs, superior food safety and the best value in today's food service marketplace.
- ▶ "Low Profile" models are designed to slide easily under custom built countertops.
- ▶ 1 1/2" (39 mm) diameter dual swivel castors. 31 7/8" (810 mm) work surface height.
- ▶ Oversized, factory balanced, refrigeration system holds 33°F to 38°F (.5°C to 3.3°C).
- ▶ All stainless steel front, top, and cabinet ends. Matching aluminum finished back.
- ▶ Attractive, NSF approved, white aluminum interior liner with 300 series stainless floor.
- ▶ Self closing doors. Positive seal, torsion type closure system.
- ▶ Entire cabinet structure and solid doors are foamed in-place using high density polyurethane insulation.

ADA & Low Profile Comparison



Standard
36" height
(915 mm)

ADA
34" height
(864 mm)

Low Profile
31 7/8" height
(810 mm)



Dual swivel castor for "LP" models.

ROUGH-IN DATA

Specifications subject to change without notice.

Chart dimensions rounded up to the nearest 1/8" (millimeters rounded up to next whole number).

Model	Doors	Capacity (Cu. Ft.) (liters)	Shelves	Cabinet Dimensions (inches) (mm)			Counter Height	HP	Voltage	Amps	NEMA Config.	Cord Length (total ft.) (total m)	Crated Weight (lbs.) (kg)
				L	D†	H*							
TUC-36-LP	2	8.5 241	4	36 ³ / ₈ 924	30 ¹ / ₈ 766	29 ³ / ₄ 756	31 ⁷ / ₈ 810	1/3 1/3	115/60/1 230-240/50/1	6.1 4.2	5-15P ▲	7 2.13	205 93

† Depth does not include 1" (26 mm) for rear bumpers.

▲ Plug type varies by country.

* Height does not include 2 1/8" (54 mm) for castors.



7/07

Printed in U.S.A.

APPROVALS:

AVAILABLE AT:

Model:
TUC-36-LP

Undercounter:
Low Profile Solid Door Refrigerator



STANDARD FEATURES

DESIGN

- True's undercounters are designed with enduring quality and value that protects your long term investment. Our commitment to using the highest quality materials and oversized refrigeration ensures exceptional food preservation.
- "Low Profile" models are designed to slide easily under custom built countertops.

REFRIGERATION SYSTEM

- Factory engineered, self-contained, capillary tube system using environmentally friendly (CFC free) 134A refrigerant.
- Oversized, factory balanced refrigeration system with guided airflow to provide uniform product temperatures.
- Extra large evaporator coil balanced with higher horsepower compressor and large condenser; maintains cabinet temperatures of 33°F to 38°F (0.5°C to 3.3°C).
- Sealed, cast iron, self-lubricating evaporator fan motor(s) and larger fan blades give True undercounter units a more efficient low velocity, high volume airflow design. This unique design ensures faster temperature recovery and shorter run times in the busiest of foodservice environments.
- Condensing unit access located in back, slides out for easy maintenance.
- Electric heated condensate pan.

CABINET CONSTRUCTION

- Exterior - 300 Series stainless steel top, front and sides with matching aluminum back.

- Interior - attractive, NSF approved, white aluminum liner. 300 series stainless steel floor with coved corners.
- Insulation - entire cabinet structure is foamed-in-place using high density, CFC free, polyurethane insulation.
- 1 1/2" (39 mm) diameter dual swivel castors permit easy placement. 31 7/8" (810 mm) work surface height.

DOORS

- Stainless steel exterior with white aluminum liner to match cabinet interior.
- Each door fitted with 12" (305 mm) long recessed handle that is foamed-in-place with a sheet metal interlock to ensure permanent attachment.
- Positive seal, self-closing doors with 90° stay open feature. Doors swing within cabinet dimensions.
- Magnetic door gaskets of one piece construction, removable without tools for ease of cleaning.

SHELVING

- Four (4) adjustable, heavy duty PVC coated wire shelves 15 9/16" L x 16" D (396 mm x 407 mm). Four (4) chrome plated shelf clips included per shelf.
- Shelf support pilasters made of same material as cabinet interior; shelves are adjustable on 1/2" (13 mm) increments

MODEL FEATURES

- Evaporator is epoxy coated to eliminate the potential of corrosion.
- NSF-7 compliant for open food product.

ELECTRICAL

- Unit completely pre-wired at factory and ready for final connection to a 115/60/1 phase, 15 amp dedicated outlet. Cord and plug set included.



115/60/1
NEMA-5-15R

OPTIONAL FEATURES/ACCESSORIES

Upcharge and lead times may apply.

- 230 - 240V / 50 Hz.
- Barrel locks (factory installed). Requires one per door.
- Additional shelves.
- 30" (762 mm) deep, 1/2" thick, white polyethylene cutting board.
- 30" (762 mm) deep, 1/2" thick, composite cutting board.
- Heavy duty 16 gauge tops.
- Standard height units with 5" (127 mm) diameter castors. 36" (915 mm) work surface height.
- ADA compliant models with 34" (864 mm) work surface height.

PLAN VIEW

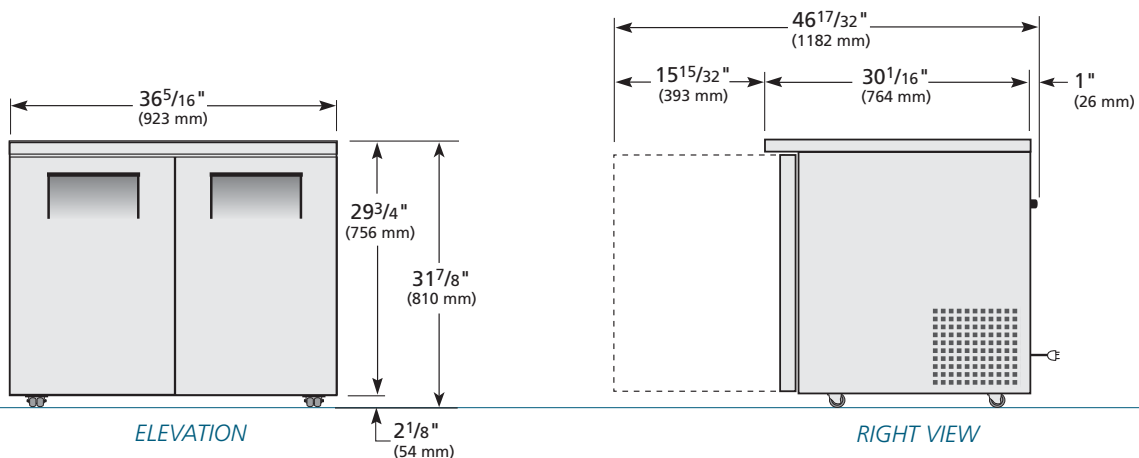

WARRANTY

One year warranty on all parts and labor and an additional 4 year warranty on compressor. (U.S.A. only)

METRIC DIMENSIONS ROUNDED UP TO THE NEAREST WHOLE MILLIMETER
SPECIFICATIONS SUBJECT TO CHANGE WITHOUT NOTICE



Model	Elevation	Right	Plan	3D
TUC-36-LP	TFPY45E	TFPY45S	TFPY25P	TFPY453

TRUE FOOD SERVICE EQUIPMENT