



**TRUE FOOD SERVICE
EQUIPMENT, INC.**



Pizzaovens.com

1.877.FOR.OVEN
367.6836

Since 1999

Project Name: _____

Location: _____

Item #: _____ Qty: _____

Model #: _____

A/A #

SIS #

Model:
TUC-44D-2

**Deep Undercounter:
Drawered Refrigerator**



TUC-44D-2

- ▶ True's deep undercounter units feature the combined advantage of undercounter placement with deeper refrigerated storage.
- ▶ Designed using the highest quality materials and components to provide the user with colder product temperatures, lower utility costs, exceptional food safety and the best value in today's food service marketplace.
- ▶ Oversized, environmentally friendly (134A) forced-air refrigeration system holds 33°F to 38°F (.5°C to 3.3°C).
- ▶ All stainless steel front, top and ends. Matching aluminum finished back.
- ▶ NSF approved, white aluminum interior liner. 300 series stainless floor with coved corners.
- ▶ Each drawer accommodates two (2) full size 12" L x 20" D x 8" H (305 mm x 508 mm x 204 mm) food pans (sold separately).
- ▶ Foamed-in-place, high density polyurethane insulation (CFC free).

ROUGH-IN DATA

Specifications subject to change without notice.

Chart dimensions rounded up to the nearest 1/8" (millimeters rounded up to next whole number).

Model	Drawers	Capacity (Cu. Ft.) (liters)	Cabinet Dimensions (inches) (mm)			HP	Voltage	Amps	NEMA Config.	Cord Length (total ft.) (total m)	Crated Weight (lbs.) (kg)
			L	D [†]	H [*]						
TUC-44D-2	2	11.4 323	44 ¹ / ₂ 1131	32 ¹ / ₄ 820	29 ³ / ₄ 756	1/5	115/60/1	5.1	5-15P	7 2.13	285 130

[†] Depth does not include 1" (26 mm) for rear and 1/4" (7 mm) for front bumpers.

^{*} Height does not include 6 1/4" (159 mm) for castors or 6" (153 mm) for optional legs.



1/08

Printed in U.S.A.

APPROVALS:

AVAILABLE AT:

Model:
TUC-44D-2

Deep Undercounter:
Drawered Refrigerator



STANDARD FEATURES

DESIGN

- True's deep undercounter units are designed with enduring quality that protects your long term investment.
- True's commitment to using the highest quality materials and oversized refrigeration systems provides the user with colder product temperatures, lower utility costs, exceptional food safety and the best value in today's food service marketplace.

REFRIGERATION SYSTEM

- Factory engineered, self-contained capillary tube system using environmentally friendly (CFC free) 134A refrigerant.
- Oversized, factory balanced refrigeration system with guided airflow to provide uniform product temperatures.
- Extra large evaporator coil balanced with higher horsepower compressor and large condenser; maintains cabinet temperatures of 33°F to 38°F (.5°C to 3.3°C) for the best in food preservation.
- Sealed, cast iron, self-lubricating evaporator fan motor(s) and larger fan blades give True undercounter units a more efficient, low velocity, high volume airflow design. This unique design ensures faster temperature recovery and shorter run times in the busiest of food service environments.
- Condensing unit is accessed from behind front grill; slides out for easy maintenance.

CABINET CONSTRUCTION

- Exterior - stainless steel front, top and ends. Matching aluminum finished back.

- Interior - attractive, NSF approved, white aluminum liner. 300 series stainless steel floor with coved corners.
- Insulation - entire cabinet structure and drawer facings are foamed-in-place using high density, CFC free, polyurethane insulation.
- 5" (127 mm) diameter stem castors - locks provided on front set. 36" (915 mm) work surface height.

DRAWERS

- Stainless steel exterior drawer facings and liners. Stainless steel drawer frames.
- Each drawer fitted with 12" (305 mm) long recessed handle that is foamed-in-place with a sheet metal interlock to ensure permanent attachment.
- Heavy-duty stainless steel drawer slides and rollers. Removable without tools for easy cleaning.
- Magnetic drawer gaskets of one piece construction, removable without tools for ease of cleaning.

PAN CAPACITY

- Each drawer accommodates (2) 12"L x 20"W x 8"D (305 mm x 508 mm x 204 mm) food pans (sold separately).

MODEL FEATURES

- Evaporator is epoxy coated to eliminate the potential of corrosion.
- Drawers will support a wide variety of incremental pan size configurations; divider bars available.
- NSF-7 compliant for open food product.

ELECTRICAL

- Unit completely pre-wired at factory and ready for final connection to a 115/60/1 phase, 15 amp dedicated outlet. Cord and plug set included.



115/60/1
NEMA-5-15R

OPTIONAL FEATURES/ACCESSORIES

Upcharge and lead times may apply.

- 6" (153 mm) standard legs.
- 6" (153 mm) seismic/flanged legs.
- 2 1/2" (64 mm) diameter castors.
- 3" (85 mm) diameter castors.
- Single utility shelf.
- Double utility shelf.
- 32 1/8" (816 mm) deep, 1/2" (13 mm) thick, white polyethylene cutting board. Requires "L" brackets.
- 32 1/8" (816 mm) deep, 1/2" (13 mm) thick, composite cutting board. Requires "L" brackets.
- Heavy duty 16 gauge tops.
- Heavy duty package - 16 gauge tops, 20 gauge drawers, sides and back with stainless interior.
- Exterior round digital temperature display (factory installed).
- Remote cabinets (condensing units supplied by others; system comes standard with 404A expansion valve and requires R404A refrigerant). Consult factory technical service department for BTU information.

PLAN VIEW

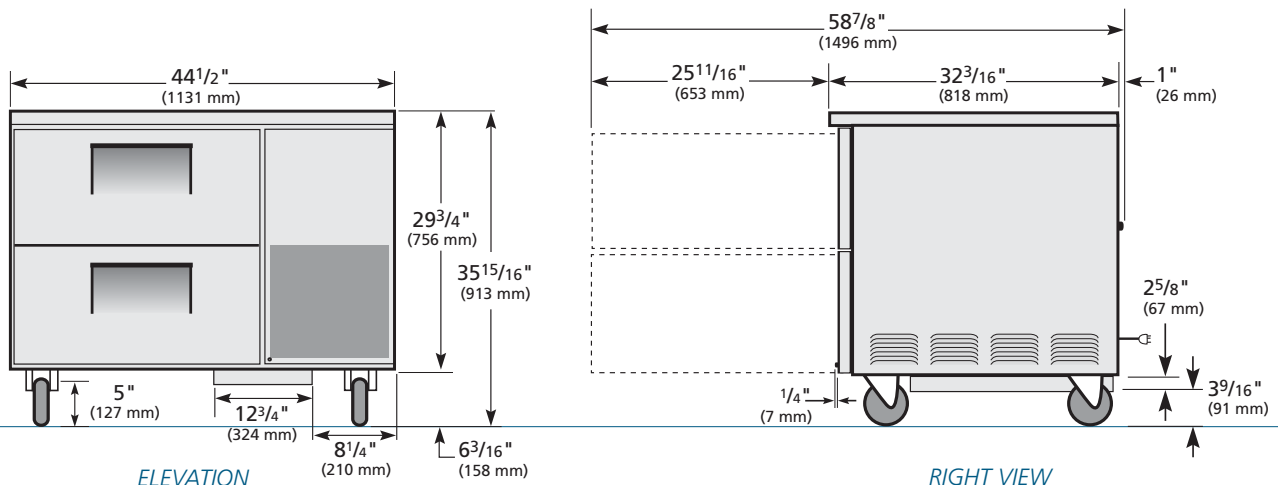

WARRANTY
One year warranty on all parts and labor and an additional 4 year warranty on compressor. (U.S.A. only)

METRIC DIMENSIONS ROUNDED UP TO THE NEAREST WHOLE MILLIMETER
SPECIFICATIONS SUBJECT TO CHANGE WITHOUT NOTICE

	Model	Elevation	Right	Plan	3D
	TUC-44D-2	TFPY65E	TFPY65S	TFPY65P	TFPY653