



**TRUE FOOD SERVICE EQUIPMENT, INC.**

1.877.FOR.OVEN  
367.6836  
Since 1999

Project Name: \_\_\_\_\_

Location: \_\_\_\_\_

Item #: \_\_\_\_\_ Qty: \_\_\_\_\_

Model #: \_\_\_\_\_

A/A #

SIS #

Model:  
**TUC-48F-LP**

**Undercounter:**  
*Low Profile Solid Door Freezer*



### TUC-48F-LP

- ▶ True's undercounters are designed with enduring quality and value that protects your long term investment. Our commitment to using the highest quality materials and oversized refrigeration insures exceptional food preservation.
- ▶ "Low Profile" models are designed to slide easily under custom built countertops.
- ▶ 1 1/2" (39 mm) diameter dual swivel castors. 31 7/8" (810 mm) work surface height.
- ▶ Oversized, factory balanced, refrigeration system holds -10°F (-23.3°C). Ideal for frozen food and ice cream.
- ▶ Exterior - 300 series stainless steel top, stainless front and sides with matching aluminum back.
- ▶ Interior - attractive, NSF approved, white aluminum liner with 300 series stainless steel floor.
- ▶ Self-closing doors. Positive seal torsion type closure system.
- ▶ Entire cabinet and solid doors are foamed-in-place using high density, CFC free, polyurethane insulation.

#### ADA & Low Profile Comparison



Standard  
36" height  
(915 mm)

ADA  
34" height  
(864 mm)

Low Profile  
31 7/8" height  
(810 mm)



Dual swivel castor for "LP" models.

### ROUGH-IN DATA

Specifications subject to change without notice.  
Chart dimensions rounded up to the nearest 1/8" (millimeters rounded up to next whole number).

Model	Doors	Capacity (Cu. Ft.) (liters)	Shelves	Cabinet Dimensions (inches) (mm)			Counter Height	HP	Voltage	Amps	NEMA Config.	Cord Length (total ft.) (total m)	Crated Weight (lbs.) (kg)
				L	D <sup>†</sup>	H*							
TUC-48F-LP	2	12.0 340	4	48 <sup>3/8</sup> 1229	30 <sup>1/8</sup> 766	29 <sup>3/4</sup> 756	31 <sup>7/8</sup> 810	1/2 1/2	115/60/1 230-	6.8 6.2	5-15P ▲	7 2.13	275 125

† Depth does not include 1" (26 mm) for rear bumpers.

\* Height does not include 2 1/8" (54 mm) for castors.

▲ Plug type varies by country.



12/05

Printed in U.S.A.

APPROVALS:

AVAILABLE AT:

Model:

**TUC-48F-LP**

**Undercounter:**

*Low Profile Solid Door Freezer*



## STANDARD FEATURES

### DESIGN

- True's commitment to using the highest quality materials and oversized refrigeration systems provides the user with colder product temperatures, lower utility costs, exceptional food safety and the best value in today's food service marketplace.
- "Low Profile" models are designed to slide easily under custom built countertops.

### REFRIGERATION SYSTEM

- Factory engineered, self-contained, capillary tube system using environmentally friendly (CFC free) R404A refrigerant.
- Oversized, factory balanced refrigeration system with guided airflow to provide uniform product temperatures.
- Extra large evaporator coil balanced with higher horsepower compressor and large condenser; maintains -10°F (-23.3°C). Ideal for frozen food and ice cream.
- Sealed, cast iron, self-lubricating evaporator fan motors and larger fan blades give True undercounter units a more efficient low velocity, high volume airflow design. This unique design insures colder standard temperature and faster recovery in high use situations.
- Condensing unit located in back; slides out for easy maintenance.
- Defrost system time-initiated, time-terminated.
- Electric heated condensate pan.

### CABINET CONSTRUCTION

- Exterior - 300 Series stainless steel top, front and sides with matching aluminum back.
- Interior - attractive, NSF approved, white aluminum liner. 300 series stainless floor with coved corners.
- Insulation - entire cabinet structure is foamed-in-place using high density, CFC free, polyurethane insulation.
- 1 1/2" (39 mm) diameter dual swivel castors permit easy placement. 31 7/8" (810 mm) work surface height.

### DOORS

- Stainless steel exterior with white aluminum liner to match cabinet interior.
- Positive seal, self-closing doors with 90° stay open feature. Doors swing within cabinet dimensions.
- Each door fitted with 12" (305 mm) long recessed handle that is foamed-in-place with a sheet metal interlock to insure permanent attachment.
- Magnetic door gaskets of one piece construction, removable without tools for ease of cleaning.

### SHELVING

- Four (4) adjustable, heavy duty PVC coated wire shelves 21 9/16" L x 16" D (548 mm x 407 mm). Four (4) chrome plated shelf clips included per shelf.
- Shelf support pilasters made of same material as cabinet interior; shelves are adjustable on 1/2" (13 mm) increments.

### MODEL FEATURES

- Evaporator is epoxy coated to eliminate the potential of corrosion.
- NSF-7 compliant for open food product.

### ELECTRICAL

- Unit completely pre-wired at factory and ready for final connection to a 115/60/1 phase - 15 amp dedicated outlet. Cord and plug set included.



115/60/1  
NEMA-5-15R

### OPTIONAL FEATURES/ACCESSORIES

Upcharge and lead times may apply.

- 230 - 240V / 50 Hz.
- Basic overshef.
- Additional shelves.
- Sandwich/salad service shelf.
- Single utility shelf.
- Double utility shelf.
- Additional shelves.
- 30" (762 mm) deep, 1/2" (13 mm) thick, white polyethylene cutting board. Requires "L" brackets.
- 30" (762 mm) deep, 1/2" (13 mm) thick, composite cutting board. Requires "L" brackets.
- Heavy duty, 16 gauge tops.
- Standard height unit with 5" (127 mm) diameter castors. 36" (915 mm) work surface height.
- ADA compliant unit with 34" (364 mm) work surface height.
- Remote cabinets (condensing unit supplied by others; system comes standard with 404A expansion valve and requires R404A refrigerant). Consult factory technical service department for BTU information.

## PLAN VIEW

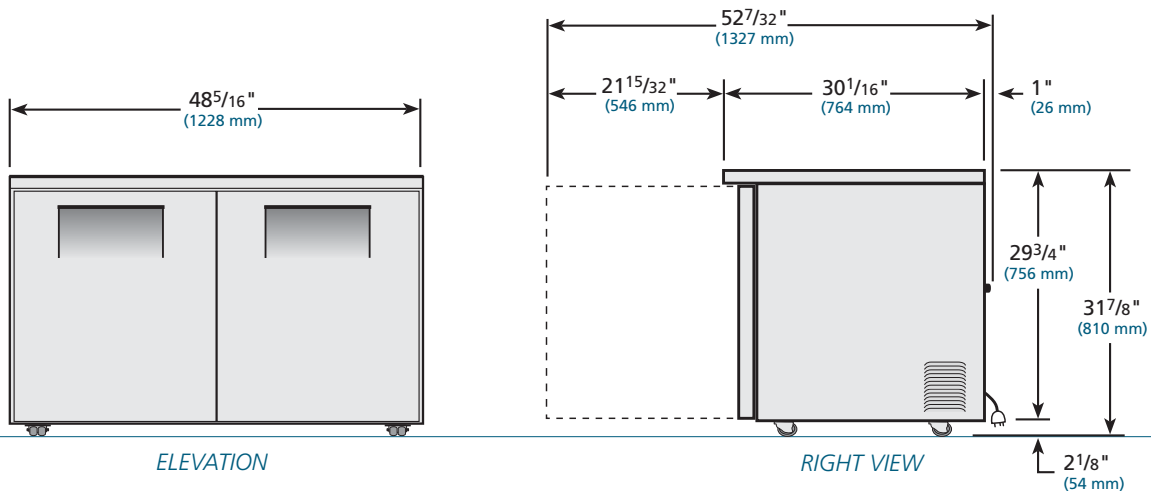

### WARRANTY

One year warranty on all parts & labor and an additional 4 year warranty on compressor. (U.S.A. only)

METRIC DIMENSIONS ROUNDED UP TO THE NEAREST WHOLE MILLIMETER

SPECIFICATIONS SUBJECT TO CHANGE WITHOUT NOTICE



Model	Elevation	Right	Plan	3D
TUC-48F-LP	TFQY102E	TFQY102S	TFQY02P	TFQY1023

**TRUE FOOD SERVICE EQUIPMENT**