



**TRUE FOOD SERVICE  
EQUIPMENT, INC.**



**Pizzaovens.com**

1.877.FOR.OVEN  
367.6836

Since 1999

Project Name: \_\_\_\_\_

Location: \_\_\_\_\_

Item #: \_\_\_\_\_ Qty: \_\_\_\_\_

Model #: \_\_\_\_\_

A/A #

SIS #

Model:  
**TUC-60-32D-2**

**Deep Undercounter:**  
*Solid Door and Drawered Refrigerator*

## TUC-60-32D-2

- ▶ True's deep undercounter unit features the combined advantage of undercounter placement with deeper refrigerated storage.
- ▶ Designed using the highest quality materials and components to provide the user with colder product temperatures, lower utility costs, exceptional food safety and the best value in today's food service marketplace.
- ▶ Oversized, environmentally friendly (134A) forced-air refrigeration system holds 33°F to 38°F (.5°C to 3.3°C).
- ▶ All stainless steel front, top and cabinet ends. Matching aluminum finished back.
- ▶ NSF approved, white aluminum interior liner. 300 series stainless floor with coved corners.
- ▶ Each drawer accommodates two (2) full size 12"L x 20"D x 8"H (305 mm x 508 mm x 204 mm) food pans (sold separately).
- ▶ Foamed-in-place, high density polyurethane insulation (CFC free).
- ▶ Heavy duty PVC coated wire shelves.
- ▶ Drawer assemblies can be located in any section of the cabinet. Location of drawers/doors must be indicated at time of ordering.



## ROUGH-IN DATA

Specifications subject to change without notice.  
Chart dimensions rounded up to the nearest 1/8" (millimeters rounded up to next whole number).

Model	Doors/ Drawers	Capacity (Cu. Ft.) (liters)	Shelves	Cabinet Dimensions (inches) (mm)			HP	Voltage	Amps	NEMA Config.	Cord Length (total ft.) (total m)	Crated Weight (lbs.) (kg)
				L	D <sup>†</sup>	H <sup>*</sup>						
TUC-60-32D-2	1/2	15.9 451	2	60 <sup>1</sup> / <sub>4</sub>	32 <sup>1</sup> / <sub>4</sub>	29 <sup>3</sup> / <sub>4</sub>	1/5	115/60/1	5.1	5-15P	7	365
				1531	820	756	1/3	230-240/50/1	3.5	▲	2.13	166

<sup>†</sup> Depth does not include 1" (26 mm) for rear bumpers or 1/4" (7 mm) for front bumper.

▲ Plug type varies by country.

<sup>\*</sup> Height does not include 6 1/4" (159 mm) for castors or 6" (153 mm) for optional legs.



7/07

Printed in U.S.A.

APPROVALS:

AVAILABLE AT:

Model:  
**TUC-60-32D-2**

**Deep Undercounter:**  
*Solid Door and Drawered Refrigerator*



**STANDARD FEATURES**

**DESIGN**

- True's deep undercounter units are designed with enduring quality that protects your long term investment.
- True's commitment to using the highest quality materials and oversized refrigeration systems provides the user with colder product temperatures, lower utility costs, exceptional food safety and the best value in today's food service marketplace.

**REFRIGERATION SYSTEM**

- Factory engineered, self-contained capillary tube system using environmentally friendly (CFC free) 134A refrigerant.
- Oversized, factory balanced refrigeration system with guided airflow to provide uniform product temperature.
- Extra large evaporator coil balanced with higher horsepower compressor and large condenser; maintains cabinet temperatures of 33°F to 38°F (.5°C to 3.3°C) for the best in food preservation.
- Sealed, cast iron, self-lubricating evaporator fan motor(s) and larger fan blades give True undercounter units a more efficient low velocity, high volume airflow design. This unique design ensures faster temperature recovery and shorter run times in the busiest of food service environments.
- Condensing unit is accessed from behind front grill; slides out for easy maintenance

**CABINET CONSTRUCTION**

- Exterior - stainless steel front, top and cabinet ends. Matching aluminum finished back.
- Interior - attractive, NSF approved, white aluminum liner. 300 series stainless floor with coved corners.
- Insulation - entire cabinet structure, solid door, and drawer facings are foamed-in-place using high density, CFC free, polyurethane insulation.

- 5" (127 mm) diameter stem castors - locks provided on front set. 36" (915 mm) work surface height.

**DOOR/DRAWERS**

- Door and drawers have stainless steel exterior with white aluminum liner to match cabinet interior.
- Door and drawers fitted with 12" (305 mm) long recessed handle that is foamed-in-place with a sheet metal interlock to ensure permanent attachment.
- Door section - door swings within cabinet dimensions.
- Magnetic drawer/door gaskets of one piece construction, removable without tools for ease of cleaning.
- Drawer assemblies can be located in any section of the cabinet. Location of drawers/doors must be indicated at time of ordering.
- Drawer section - heavy-duty stainless steel drawer slides and rollers.

**SHELVING**

- Two (2) adjustable, heavy duty PVC coated wire shelves 17<sup>1</sup>/<sub>4</sub>" L x 28" D (439 mm x 712 mm). Four (4) chrome plated shelf clips included per shelf.
- Shelf support pilasters made of same material as cabinet interior; shelves are adjustable on 1/2" (13 mm) increments.

**DRAWER PAN CAPACITY**

- Each drawer accommodates two (2) 12" L x 20" W x 8" D (305 mm x 508 mm x 204 mm), four (4) 1/2 pans, or six (6) 1/3 food pans (sold separately).

**MODEL FEATURES**

- Evaporator is epoxy coated to eliminate the potential of corrosion.
- Drawers will support a wide variety of incremental pan size configurations; divider bars available.
- NSF-7 compliant for open food product.

**ELECTRICAL**

- Unit completely pre-wired at factory and ready for final connection to a 115/60/1 phase, 15 amp dedicated outlet. Cord and plug set included.



115/60/1  
NEMA-5-15R

**OPTIONAL FEATURES/ACCESSORIES**

Upcharge and lead times may apply.

- 230-240V/50Hz.
- 6" (153 mm) standard legs.
- 6" (153 mm) seismic/flanged legs.
- 2<sup>1</sup>/<sub>2</sub>" (64 mm) diameter castors.
- 3" diameter castors.
- Single utility shelf.
- Double utility shelf.
- 32<sup>1</sup>/<sub>8</sub>" (816 mm) deep, 1/2" (13 mm) thick, white polyethylene cutting board. Requires "L" brackets.
- 32<sup>1</sup>/<sub>8</sub>" (816 mm) deep, 1/2" (13 mm) thick, composite cutting board. Requires "L" brackets.
- Heavy duty 16 gauge tops.
- Heavy duty package (16 gauge tops, 20 gauge door, sides and back with stainless interior).
- Exterior round digital temperature display (factory installed).
- Remote cabinets (condensing unit supplied by others; system comes standard with 404A expansion valve and requires R404A refrigerant). Consult factory technical service department for BTU information.

**PLAN VIEW**

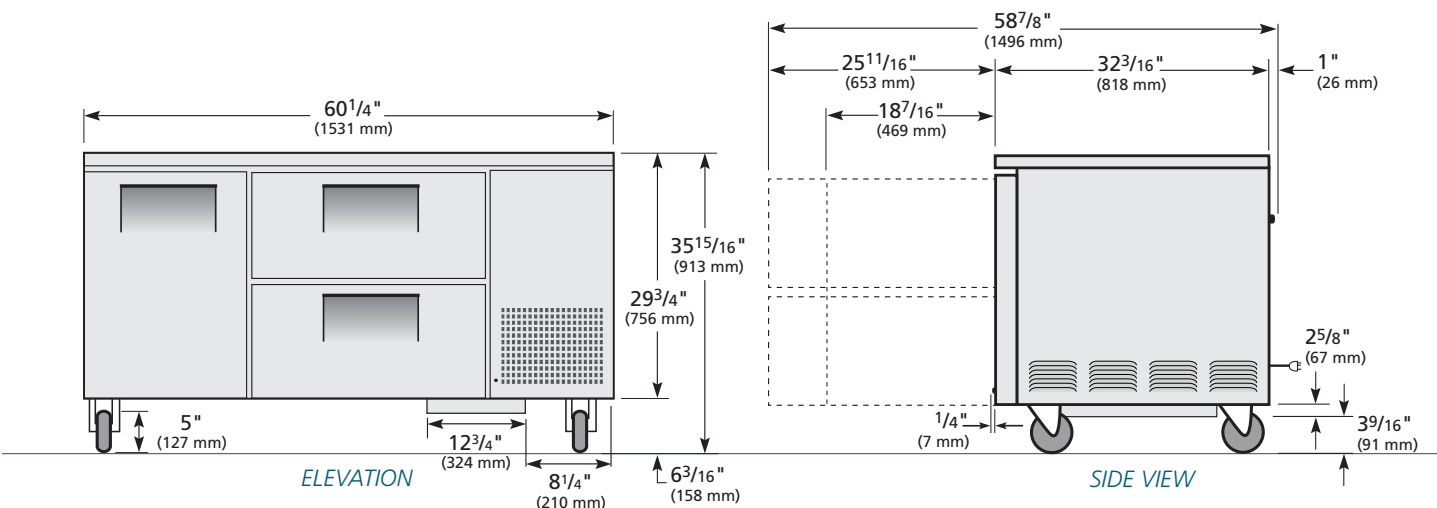

**WARRANTY**  
One year warranty on all parts & labor and an additional 4 year warranty on compressor. (U.S.A. only)

METRIC DIMENSIONS ROUNDED UP TO THE NEAREST WHOLE MILLIMETER  
SPECIFICATIONS SUBJECT TO CHANGE WITHOUT NOTICE



Model	Elevation	Right	Plan	3D
TUC-60-32D-2	TFPY43E	TFPY65S	TFPY43P	TFPY433