



**TRUE FOOD SERVICE
EQUIPMENT, INC.**



Pizzaovens.com

1.877.FOR.OVEN
367.6836
Since 1999

Project Name: _____

A/A #

Location: _____

Item #: _____ Qty: _____

SIS #

Model #: _____

Model:
T-23DT-G

DT Series:
Reach-In Dual Temperature Glass Door Refrigerator/Freezer



T-23DT-G

- ▶ Designed using the highest quality materials and components to provide the user with colder product temperatures, lower utility costs, exceptional food safety and the best value in today's food service marketplace.
 - ▶ Refrigerator located in top section; freezer on bottom.
 - ▶ Equipped with two, self-contained, independent refrigeration systems. Oversized and factory balanced; refrigerator section holds 33°F to 38°F (.5°C to 3.3°C); freezer holds -10°F (-23.3°C).
 - ▶ Energy efficient, "Low-E", double pane thermal tempered glass door in refrigerator section.
 - ▶ Energy efficient, triple pane thermal insulated glass door in freezer section.
 - ▶ Adjustable, heavy duty PVC coated shelves.
 - ▶ Positive seal self-closing doors. Lifetime guaranteed door hinges and torsion type closure system.
- Bottom mounted units feature:**
- ▶ "No stoop" lower shelf.
 - ▶ Storage on top of cabinet.
 - ▶ Compressor performs in coolest, most grease free area of kitchen.
 - ▶ Easily accessible condenser coil for cleaning.

ROUGH-IN DATA

Specifications subject to change without notice.
Chart dimensions rounded up to the nearest 1/8" (millimeters rounded up to next whole number).

Model	Glass Doors	Capacity (Cu. Ft.) (liters)		# of Shelves	Cabinet Dimensions (inches) (mm)			HP		Voltage	Amps	NEMA Config.	Cord Length (total ft.) (total m)	Crated Weight (lbs.) (kg)
		Ref.	Frz.		L	D†	H*	Ref.	Frz.					
T-23DT-G	2	11 312	8 227	3	27 686	29 ³ / ₄ 756	78 ³ / ₈ 1991	1/5 1/5	1/2 1/2	115/60/1 230-240/50/1	15.6 7.3	5-20P ▲	9 2.74	360 164

* Height does not include 5" (127 mm) for castors or 6" (153 mm) for optional legs.

▲ Plug type varies by country.

† Depth does not include 1³/₈" (35 mm) for door handles.



APPROVALS:

3/05

Printed in U.S.A.

Model:
T-23DT-G

DT Series:
Reach-In Dual Temperature Glass Door
Refrigerator/Freezer



STANDARD FEATURES

DESIGN

- True's glass door reach-in's are designed with enduring quality that protects your long term investment.
- True's commitment to using the highest quality materials and oversized refrigeration systems provides the user with colder product temperatures, lower utility costs, exceptional food safety and the best value in today's food service marketplace.

REFRIGERATION SYSTEM

- Equipped with two, independent, factory engineered, self-contained, capillary tube refrigeration systems using environmentally friendly (CFC free) refrigerant. Refrigerator uses 134A and freezer uses R404A.
- Refrigerator located in top section; freezer on bottom.
- Extra large evaporator coils balanced with higher horsepower compressors and large condensers; maintain colder standard temperatures for the best in food preservation. Refrigerator holds 33°F to 38°F (5°C to 3.3°C); freezers holds -10°F (-23.3°C).
- Sealed, cast iron, self-lubricating evaporator fan motor(s) and larger fan blades give True reach-in's a more efficient low velocity, high volume airflow design. This unique design insures faster temperature recovery and shorter run times in the busiest of foodservice environments.
- Bottom mounted condensing unit positioned for easy cleaning. Compressor runs in coolest and most grease free area of the kitchen. Allows for storage area on top of unit.
- Freezer defrost system is time initiated, time terminated.

CABINET CONSTRUCTION

- Exterior - 300 series stainless steel front, grill and shroud. Anodized quality aluminum exterior ends, back and top.
- Interior - attractive, NSF approved, white aluminum liner. 300 series stainless floor with coved corners.
- Insulation - entire cabinet structure and glass door are foamed-in-place using high density, CFC free, polyurethane insulation.
- Cabinet mounted on a welded, heavy duty galvanized frame rail. Rail dipped in rust inhibiting enamel paint for corrosion protection inside and out.
- Frame rail fitted with 4" (102 mm) diameter stem castors - locks provided on front set.

DOORS

- "Low-E", double pane thermal glass assembly in refrigerator door. Triple pane thermal glass assembly in freezer door.
- Positive seal self-closing doors. Lifetime guaranteed door hinges and torsion type closure system.
- Each glass door is fitted with a 15" (381 mm) long extruded aluminum handle.
- Magnetic door gaskets of one piece construction, removable without tools for ease of cleaning.

SHELVING

- Three (3) adjustable, heavy duty PVC coated wire shelves 27⁷/₈" L X 23¹/₄" D (582 mm x 591 mm). Four (4) chrome plated shelf clips included per shelf.
- Shelf support pilasters made of same material as cabinet interior; shelves are adjustable on 1/2" (13 mm) increments.

LIGHTING

- Fluorescent interior lighting. Each glass door utilizes full-length, patented, integrated door light (IDL) system. Safety shielded.

MODEL FEATURES

- Two (2) exterior mounted temperature monitors. One for refrigerator section and one for freezer section.
- Evaporator is epoxy coated to eliminate the potential of corrosion.
- NSF-7 compliant for open food products.

ELECTRICAL

- Unit completely pre-wired at factory and ready for final connection to a 115/60/1 phase - 20 amp dedicated outlet. Cord and plug set included.



115/60/1
NEMA-5-20R

OPTIONAL FEATURES/ACCESSORIES

Upcharge and lead times may apply.

- 230-240V/50Hz.
- 6" (153 mm) standard legs.
- 6" (153 mm) seismic/flanged legs.
- Additional shelves.
- Novelty baskets.
- Half bun tray rack (refrigerator section only). Holds up to eleven 18" L x 26" D (458 mm x 661 mm) sheet pans (sold separately).
- Remote cabinets (condensing unit supplied by others), consult factory technical service department for BTU information.

PLAN VIEW

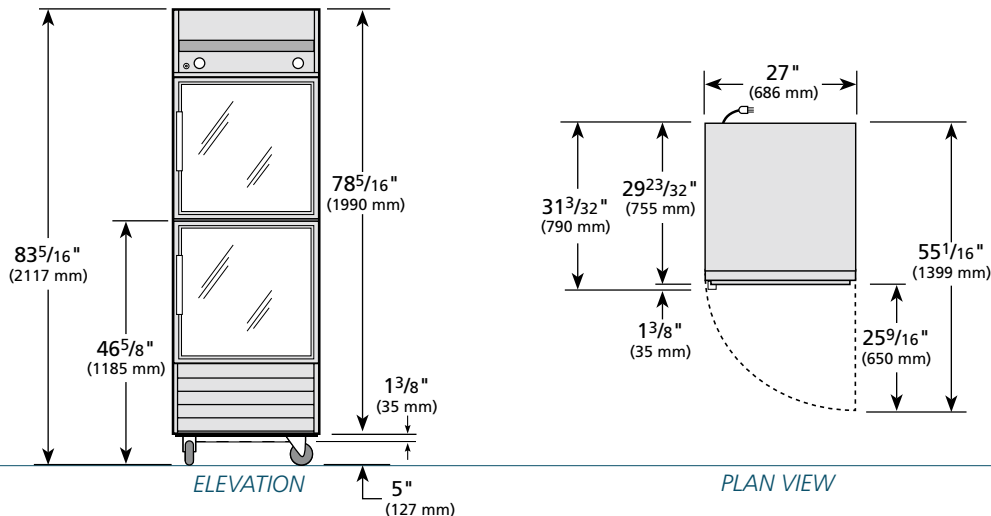

WARRANTY
One year warranty on all parts & labor and an additional 4 year warranty on compressor. (U.S.A. only)

METRIC DIMENSIONS ROUNDED UP TO THE NEAREST WHOLE MILLIMETER
SPECIFICATIONS SUBJECT TO CHANGE WITHOUT NOTICE

	Model	Elevation	Right	Plan	3D
	T-23DT-G	TFEY65E	TFGY08S	TFEY06P	TFEY653

TRUE FOOD SERVICE EQUIPMENT