



# Solid Door Freezers

## Stainless Steel Interior and Front Digitally Controlled Uniform Temperature



MSF-23NM



MSF-49NM

- **DIGITAL TEMPERATURE CONTROL SYSTEM**  
Provides precise and constant temperature. This level of precision allows food products to remain fresh over an extended period of time.
- **HIGH-TECH MONITOR**  
The unit will beep if the door has been opened for more than 5 minutes. The monitor digitally displays the present temperature. You can easily change the temperature by adjusting the thermostat.
- **SELF-DIAGNOSTIC SYSTEM**  
Displays current status of the freezer.
- **AUTOMATIC EVAPORATOR FAN MOTOR DELAYS**  
When the door is opened.
- **EFFICIENT REFRIGERATION SYSTEM**  
Turbo Air's solid door freezers are designed with over-sized evaporators and condensers for faster cooling and greater efficiency.
- **BOTTOM MOUNT COMPRESSOR**  
All units feature a bottom mount compressor for energy savings, high efficiency and easy service.
- **STANDARD BACKGUARD IMPROVES AIRFLOW**
- \* A certificated member of NMSDC
- \* **CEC. California Energy Commission Certificated**
- \* **MEA. City of New York Building Department Approved**

- **STAINLESS STEEL INTERIOR AND FRONT**  
The New Maximum Series are constructed of high quality stainless steel on the interior and front. Our stainless steel construction will ensure a bright, dent-resistant and durable finish for years to come.
- **HOLDS -10°F ~5°F**
- **ADJUSTABLE, HEAVY DUTY PVC COATED WIRE SHELVES**
- **SELF-CLOSING AND STAY OPEN DOOR FEATURES**
- **SOLID AND STURDY STAINLESS STEEL GRILLE**
- **MINIMUM WATTAGE HEATER IN CABINET FRAME AND DOOR**
- **INCANDESCENT INTERIOR LIGHTING**
- **FOAMED WITH POLYURETHANE, HIGH-DENSITY CELL INSULATION (CFC FREE)**
- **4" SWIVEL CASTERS (STANDARD)**
- **TRAY RACK AVAILABLE**  
All models are standard to accept full size door tray racks. Lamp shield must be removed prior to installation and re-assembled after installing racks.



LISTED COMMERCIAL REFRIGERATOR AND/OR FREEZER 43BK



CEC  
MEA



Model	Swing Door	CU./FT.	#of Shelves	HP	AMPS	Weight	L D H
MSF-23NM	1	23	3	1/2	8.7	284	27.0 x 30.7 x 78.1
MSF-49NM	2	49	6	3/4	10.5	463	54.4 x 30.7 x 78.1

\* Height does not include 5" for caster height.

# Solid Door Refrigerators

## CABINET INTERIOR/EXTERIOR SPECIFICATIONS

ELECTRICAL DATA	MSR-23NM	MSR-49NM
Voltage	115/60-1	115/60-1
Feed Wires (with ground)	3	3
Amperes	5.5 A	9.2 A
<b>SHIPPING DATA</b>		
Length-Crated (in)	29.3	56.8
Depth-Crated (in)	33.7	33.7
Height-Crated (in)	84.3	84.3
Volume Crated (cu.ft)	48.1	87.3
Net Weight (lbs)	258	412
Weight After Packing (lbs)	308.6	485
<b>DIMENSIONAL DATA</b>		
# of Doors	1	2
Cubic Feet	23	49
Rack Capacity	1	2
Length Overall (in)	27	54.4
Depth Overall (in)	30.8	30.8
Height Overall (in)(with caster)	82.9	82.9
Interior Dimension (LxDxH)	23x24.8x60.4	50.5x24.8x60.4
Shelf Size	21.6x23.3	24.4x23.3
# of Shelves	3	6



MSR-23NM



MSR-49NM



\*Design and specifications subject to change without notice.

(unit : inch)

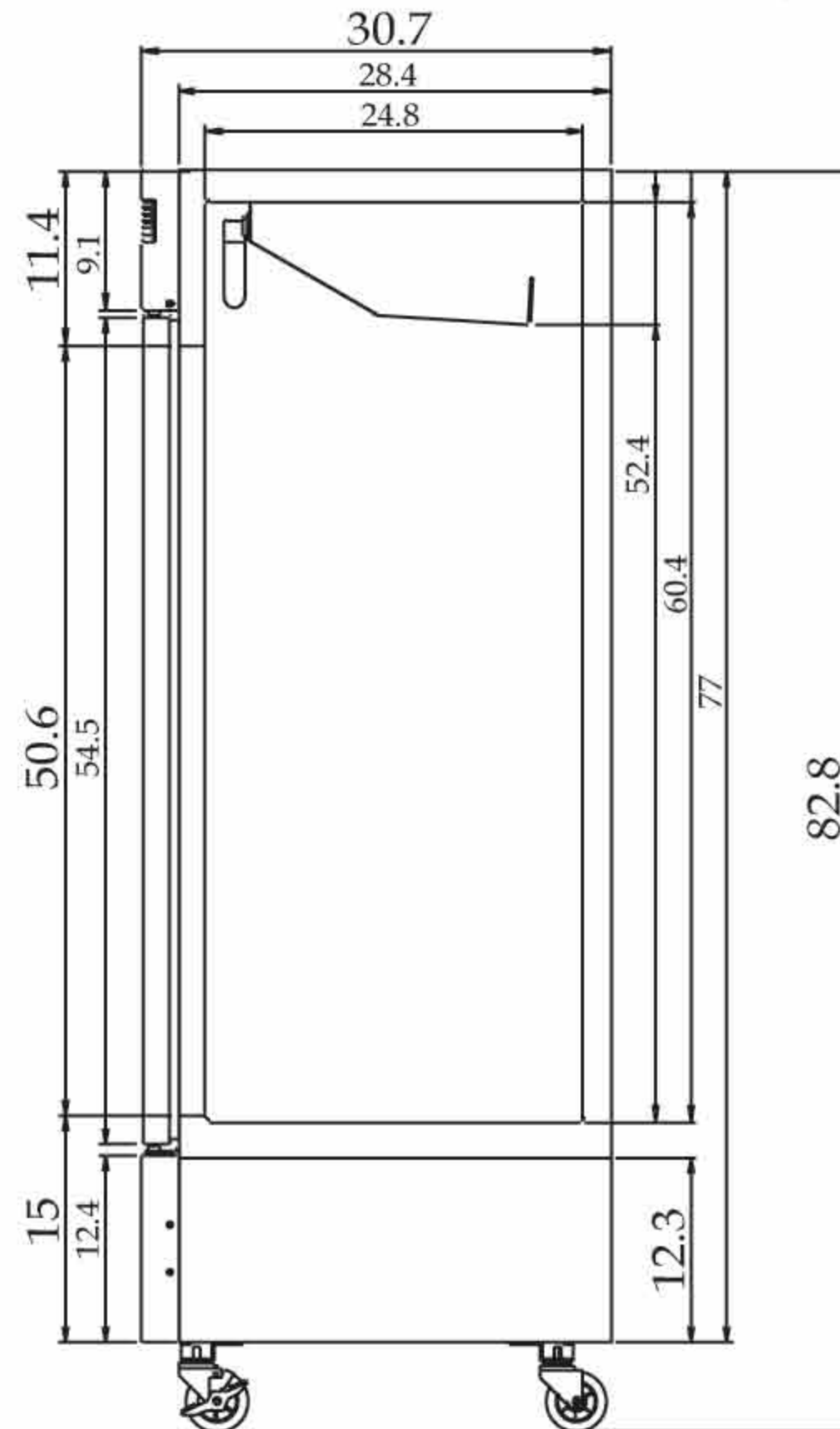
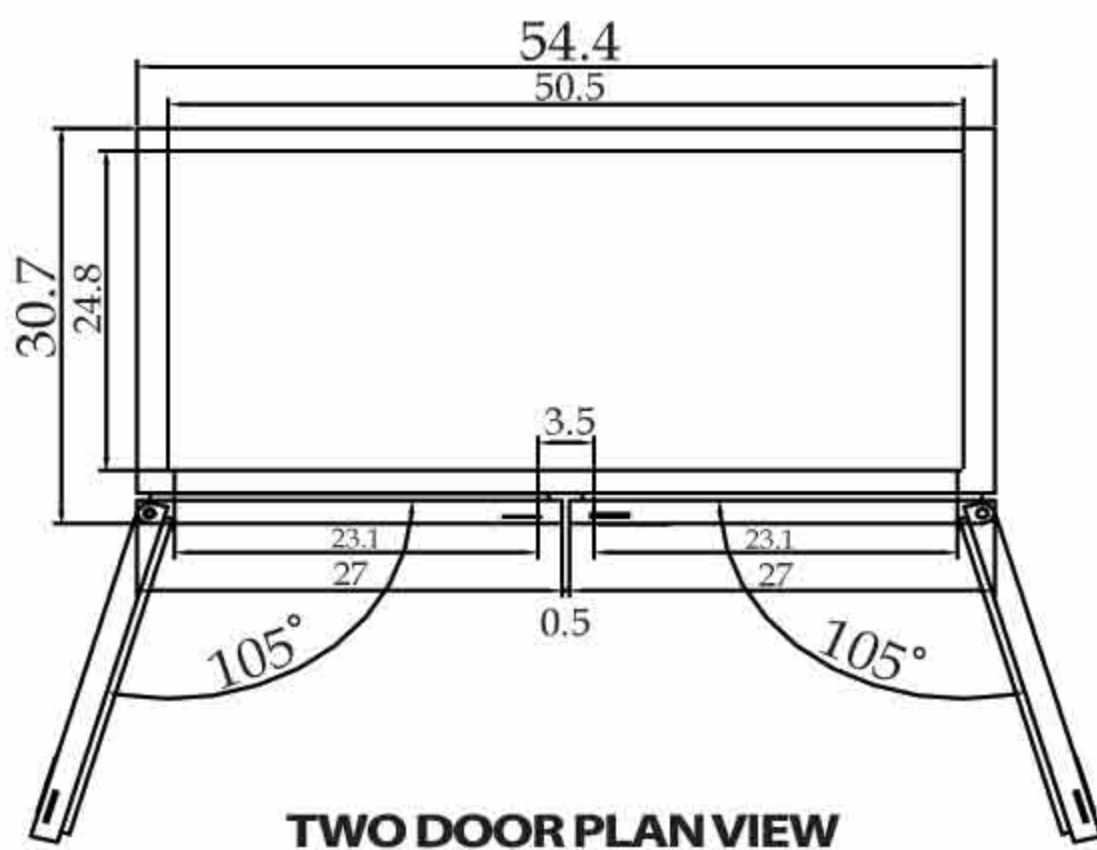
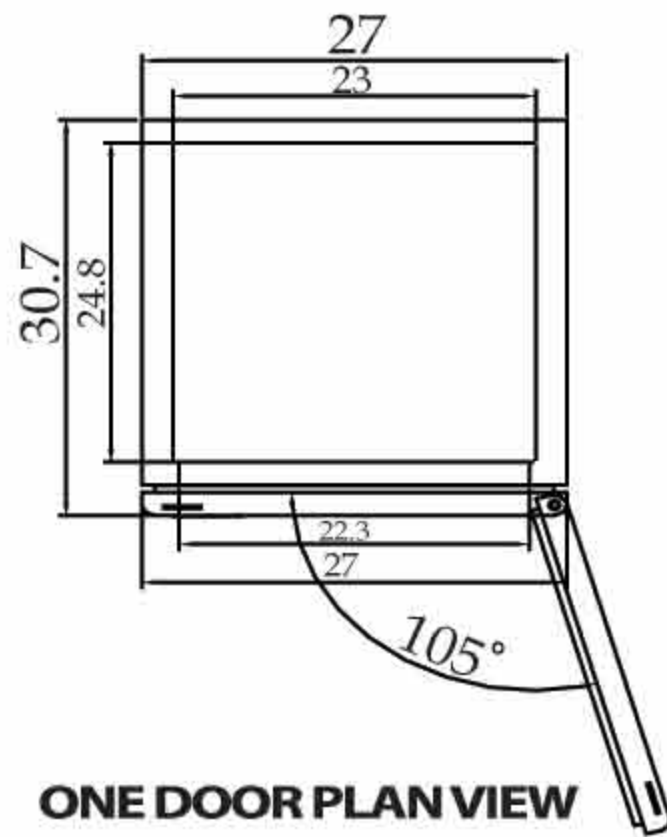

SIDE VIEW