



Model PS-6-24BG-2626

Specification:

Medium-Duty Range, Model: _____, with total BTU/Hr rating of: _____, when fueled by natural/propane gas. Finish is to be stainless steel, front and sides. Unit is to have 6" (152mm) legs with adjustable feet.

Oven: Oven door is to be one piece. Oven interior is to be porcelainized with a heavy-duty, "keep cool" door handle. Standard oven to come with a thermostat having temperature range from Low to 500°F, (260°C). Oven interior is to have one chrome plated oven rack and four-position rack guides.

Open Burners: are to be 30,000 BTU/Hr per burner, (NAT)/28,000 BTU/Hr (PRO) per burner, with center pilot and a one-piece, cast iron top grate over two open burners.

Broiler/Griddles: are to have 5/8" (16mm), thick steel plate with 3" (76mm), wide grease trough. Burners are to be rated 14,000 BTU/Hr per burner. One burner per 12" (305mm), broiler/griddle; three burners per 24" (610mm), broiler/griddle. Burners provide simultaneous heat to both broiler and griddle.



Standard Features:

- Stainless steel front, sides and high shelf
- Large, durable control knobs
- 6" (152mm), chrome plated adjustable legs
- Pressure regulator; 3/4" (19mm), rear gas connection
- One year limited warranty on parts and labor, (USA & Canada)

Open Burners

- One-piece, cast iron, lift-off top grate; each 12" (305mm), wide x 25" (635mm), deep
- Geometric burners with center pilot; 30,000 BTU/Hr per burner, (NAT)/28,000 BTU/Hr (PRO) per burner
- Large capacity, removable, aluminized drip pan

Broiler/Griddle

- 5/8" (16mm) thick steel plate with manual valve control
- 3" (76mm) wide drip trough
- 14,000 BTU/Hr cast iron burner(s); one per 12" broiler/griddle, three per 24" broiler/griddle
- Aluminized drip tray
- One chrome plated broiler rack on 2-position rack guides

Ovens

- Standard, full-size oven: 26 1/4"W x 22"D x 13 1/2"H interior, (667mm x 559mm x 343mm)
- Standard oven rated 35,000 BTU/Hr
- Space-saver oven rated 25,000 BTU/Hr
- Thermostat with temperature range of Low to 500°F, (260°C)
- Four-position removable rack guides
- One chrome plated oven rack
- Porcelainized oven interior, (excluding top)
- Strong, keep-cool oven door handle

Optional Features:

- Interconnecting gas line to range-mounted broiler, (salamander or cheesemelter)
- Extra oven racks
- Casters; 6" (152mm), swivel casters, set of four; two locking
- Hot top in lieu of two open burners
- Stainless steel work surface in lieu of two open burners
- Grooved griddle
- Convection oven w/1725RPM, 1/3HP fan motor, three chrome plated oven racks on three-position rack guides, (not available in 'space-saver' size)
- Cabinet base with or without stainless steel doors
- Reverse broiler/griddle location, (left side)
- Stainless steel legs
- Flanged feet



Model Number	Description	Total BTU/Hr	Shipping Information		
			Lbs.	Kg	Cube
PS-4-12BG-26	36" Wide, Four Open Burners, 12" Broiler/Griddle w/26" Oven	169,000	576	166	38.0
PS-4-24BG-2020	48" Wide, Four Open Burners, 24" Broiler/Griddle w/(2) 20" Ovens	212,000	730	130	51.0
PS-6-24BG-26	60" Wide, Six Open Burners, 24" Broiler/Griddle w/26" Oven	257,000	736	175	63.5
PS-6-24BG-2626	60" Wide, Six Open Burners, 24" Broiler/Griddle w/(2) 26" Ovens	292,000	855	138	63.5

Specifications:

Widths	Depth	Height		Oven Interior			Combustible Wall Clearance	
		w/Legs	w/o Legs	Height	Depth	Width*	Sides	Rear
36"/48"/60" (914/1219/1524)	32" (813mm)	43-3/8" (1102mm)	37-3/8" (949mm)	13-1/2" (343mm)	22" (559mm)	26-1/4" (667mm)	9" (229mm)	6" (152mm)

* Space-saver oven interior is 20-1/4" in width, 25,000 BTU/Hr

These appliances are intended for commercial use by professionally trained personnel. It is the responsibility of the installer to ensure that installation complies with national and local codes.

Burner Ratings (BTU/Hr)		
Open	Broiler/Griddle	Oven*
30,000	14,000	35,000

Operating Pressure		Entry Clearances	
Natural	Propane	Crated	Uncrated*
4.5" WC	10.0" WC	46" (1168mm)	34" (864mm)

**With "RC" option: 39" (991mm)

Optional Convection Oven (per oven)			
115V	60Hz	1 Ø	5 Amps
6-ft. cord and plug included.			

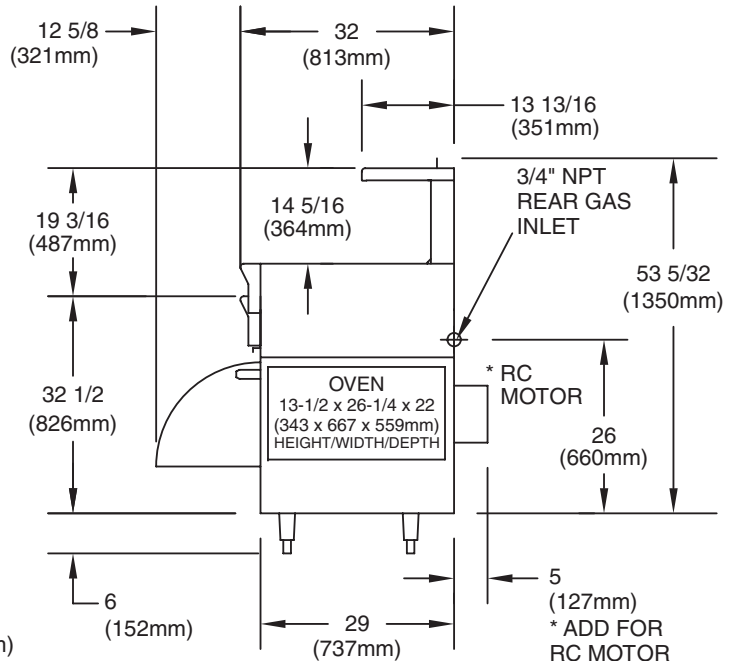
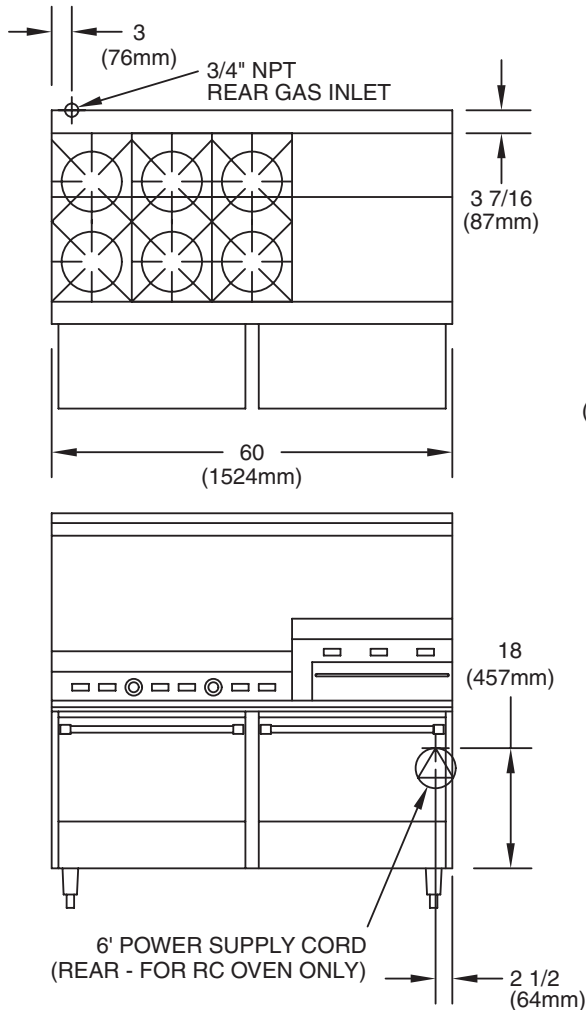

Performer S Series Broiler/Griddle Range