



*Model SX-10-2626*

### Specification:

Medium-Duty Range, Model: \_\_\_\_\_, with total BTU/Hr rating of: \_\_\_\_\_, when fueled by natural/propane gas. Finish is to be stainless steel, front and sides. Unit is to have 6" (152mm) legs with adjustable feet.

Oven: Oven door is to be one piece. Oven interior is to be porcelainized with a heavy-duty, "keep cool" door handle. Standard oven to come with a thermostat having temperature range from Low to 500°F, (260°C). Oven interior is to have one chrome plated oven rack and two-position rack guides.

Open Burners: are to be 22,000 BTU/Hr per burner, with center pilot and a one-piece, cast iron top grate over two open burners.

Griddles: are to be 5/8" (16mm), thick steel plate with 4-1/2" (114mm), wide grease trough. Burners are to be rated 20,000 BTU/Hr per burner. One burner per 12" (305mm), section.



### Standard Features:

- Stainless steel front, sides, 4-1/2" plate rail, and high shelf
- Durable, easy to read control knobs
- 6" (152mm), chrome plated adjustable legs
- Pressure regulator; 3/4" (19mm), rear gas connection
- One year limited warranty on parts and labor, (USA & Canada)

### Standard on Applicable Models:

#### Open Burners

- One-piece, cast iron, lift-off top grate; each 12" (305mm), wide x 25" (635mm), deep
- Octagonal burners with center pilot; 22,000 BTU/Hr per burner
- Large capacity, removable, aluminized drip pan

#### Griddle, (std on left, working depth: 20-1/2"/521mm)

- 5/8" (16mm) thick steel plate with manual valve control
- 4-1/2" (114mm), wide drip trough to internal grease drawer
- One burner every 12" (305mm), section, rated 20,000 BTU/Hr

#### Ovens

- Standard, full-size oven: 26 1/4"W x 22"D x 13 1/2"H interior, (667mm x 559mm x 343mm)
- Standard oven rated 30,000 BTU/Hr
- Thermostat with temperature range of Low to 500°F, (260°C)
- Two-position oven rack guides
- One chrome plated oven rack
- Porcelainized oven interior, (excluding top)
- Strong, keep-cool oven door handle

### Optional Features:

- Interconnecting gas line to range-mounted broiler, (salamander or cheesemelter)
- Stainless steel, 5" (127mm), stub back
- Extra oven racks
- Casters; 6" (152mm), swivel casters, set of four; two locking
- Open-cabinet storage base, (replaces oven)
- 6" stainless steel legs
- Flanged feet





Item #: \_\_\_\_\_

Model: SX-(60)

Product Name: SunFire Series 60" Range

Model Number	Description	Total BTU/Hr	Shipping Information		
			Lbs.	Kg	Cube
SX-10-2626	Ten Open Burners w/(2) 26" Ovens	280,000	756	343	63.5
SX-10-26	Ten Open Burners w/(1) 26" Oven, Open Storage	250,000	710	322	63.5
SX-24G-6-2626	24" Griddle, Six Open Burners w/(2) 26" Ovens	232,000	793	360	63.5
SX-24G-6-26	24" Griddle, Six Open Burners w/(1) 26" Oven, Open Storage	202,000	719	326	63.5

Width	Depth	Height		Oven Interior			Combustible Wall Clearance	
		w/Legs	w/o Legs	Height	Depth	Width	Sides	Rear
60" (1524mm)	33-1/8" (841mm)	38-1/2" (978mm)	32-1/2" (826mm)	13-1/2" (343mm)	22" (559mm)	26-1/4" (667mm)	9" (229mm)	6" (152mm)

Burner Ratings (BTU/Hr)		
Open	Griddle	Oven
22,000	20,000	30,000

Operating Pressure		Entry Clearances	
Natural	Propane	Crated	Uncrated
4.5" WC	10.0" WC	46" (1168mm)	34" (864mm)

These appliances are intended for commercial use by professionally trained personnel. It is the responsibility of the installer to ensure that installation complies with national and local codes.

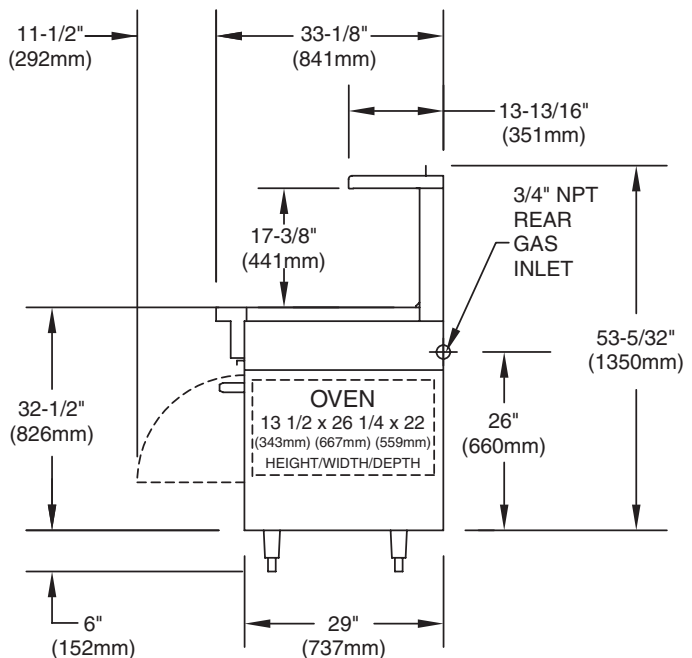
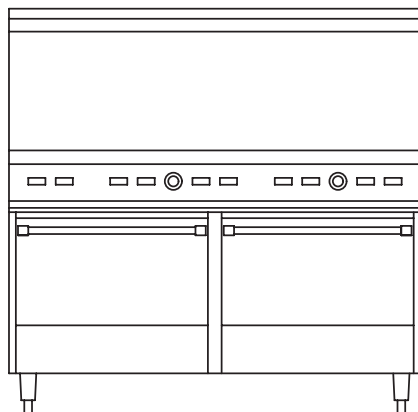
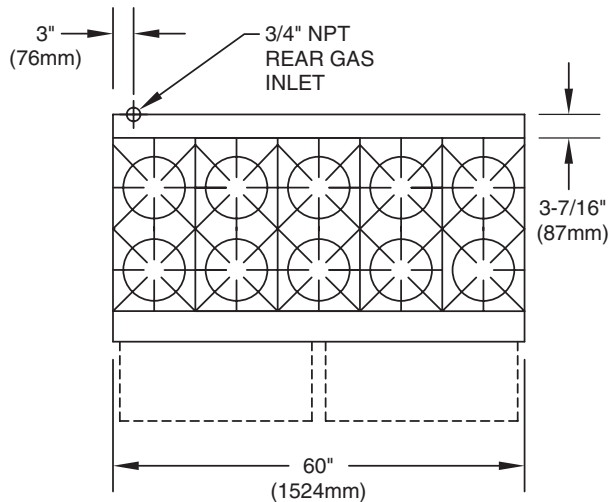

SunFire Series 60" Range

