



Model SX-6-24BG-2626

Specification:

Medium-Duty Range, Model: _____, with total BTU/Hr rating of: _____, when fueled by natural/propane gas. Finish is to be stainless steel, front and sides. Unit is to have 6" (152mm) legs with adjustable feet.

Oven: Oven door is to be one piece. Oven interior is to be porcelainized with a heavy-duty, "keep cool" door handle. Standard oven to come with a thermostat having temperature range from Low to 500°F, (260°C). Oven interior is to have one chrome plated oven rack and four-position rack guides.

Open Burners: are to be 22,000 BTU/Hr per burner, with center pilot and a one-piece, cast iron top grate over two open burners.

Broiler/Griddles: are to have 5/8" (16mm), thick steel plate with 4-1/2" (114mm), wide grease trough. Burners are to be rated 14,000 BTU/Hr per burner. Three burners per 24" (610mm), broiler/griddle. Burners provide simultaneous heat to both broiler and griddle.

Standard Features:

- Stainless steel front, sides, 4-1/2" plate rail, and high shelf
- Durable, easy to read control knobs
- 6" (152mm), chrome plated adjustable legs
- Pressure regulator; 3/4" (19mm), rear gas connection
- One year limited warranty on parts and labor, (USA & Canada)

Open Burners

- One-piece, cast iron, lift-off top grate; each 12" (305mm), wide x 25" (635mm), deep
- Octagonal burners with center pilot; 22,000 BTU/Hr per burner
- Large capacity, removable, aluminized drip pan

Broiler/Griddle

- 5/8" (16mm) thick steel plate with manual valve control
- Available on right side only; working depth: 20-1/2" (521mm)
- 4-1/2" (114mm) wide drip trough
- 14,000 BTU/Hr cast iron burner(s); three per 24" broiler/griddle
- Aluminized drip tray
- One chrome plated broiler rack on 2-position rack guides

Ovens

- Standard, full-size oven: 26 1/4"W x 22"D x 13 1/2"H interior, (667mm x 559mm x 343mm)
- Standard oven rated 30,000 BTU/Hr
- Thermostat with temperature range of Low to 500°F, (260°C)
- Two-position oven rack guides
- One chrome plated oven rack
- Porcelainized oven interior, (excluding top)
- Strong, keep-cool oven door handle

Optional Features:

- Interconnecting gas line to range-mounted broiler, (salamander or cheesemelter)
- Extra oven racks
- Casters; 6" (152mm), swivel casters, set of four; two locking
- Open-cabinet storage base, (replaces oven)
- 6" stainless steel legs
- Flanged feet





Item #: _____
 Model: SX-BG
 Product Name: SunFire Series 60"
 Broiler/Griddle Range

Model Number	Description	Total BTU/Hr	Shipping Information		
			Lbs.	Kg	Cube
SX-6-24BG-26	60" Wide, Six Open Burners, 24" Broiler/Griddle w/26" Oven	204,000	736	333	63.5
SX-6-24BG-2626	60" Wide, Six Open Burners, 24" Broiler/Griddle w/(2) 26" Ovens	234,000	855	387	63.5

Specifications:

Width	Depth	Height		Oven Interior			Combustible Wall Clearance	
		w/Legs	w/o Legs	Height	Depth	Width*	Sides	Rear
60" (1524mm)	33-1/8" (841mm)	43-3/8" (1102mm)	37-3/8" (949mm)	13-1/2" (343mm)	22" (559mm)	26-1/4" (667mm)	9" (229mm)	6" (152mm)

These appliances are intended for commercial use by professionally trained personnel. It is the responsibility of the installer to ensure that installation complies with national and local codes.

Burner Ratings (BTU/Hr)		
Open	Broiler/Griddle	Oven
22,000	14,000	30,000

Operating Pressure		Entry Clearances	
Natural	Propane	Crated	Uncrated
4.5" WC	10.0" WC	46" (1168mm)	34" (864mm)

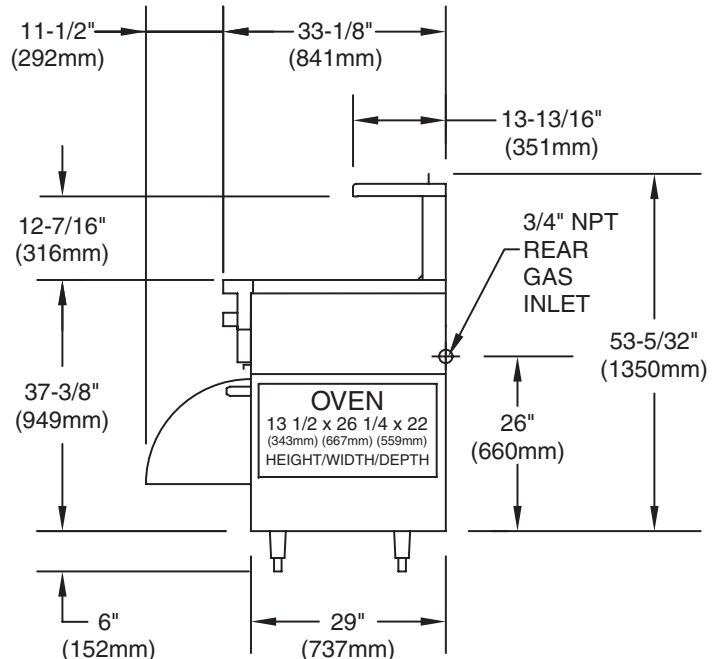
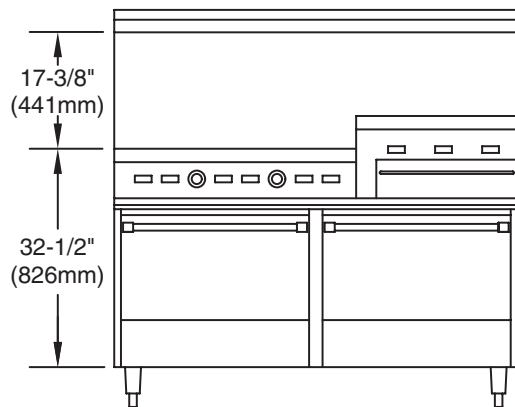
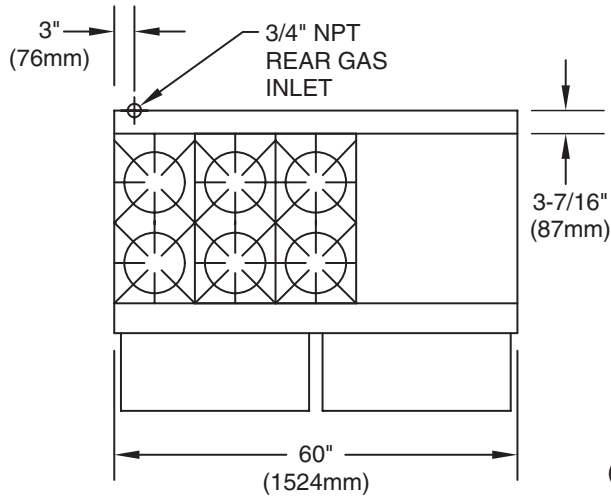

SunFire Series Broiler/Griddle Range

