

FOOD MIXER

Model W20A



General Description

The Varimixer Model W20A is our most rugged 21 quart mixer, combining an industry leading 1 hp drive with our proven variable speed transmission. This combination provides plenty of torque at the beater shaft for maximum batch sizes. The W20A features very efficient agitators to quickly produce quality food products.

The W20A can be equipped with a stainless steel automatic bowl scraper. The bowl scraper eliminates intermediate stopping during recipe preparation, saving time and improving sanitation.

The W20A features a wide agitator speed range from 100 rpm to 450 rpm. The W20A has the versatility and the performance to handle all your mixing needs from the heaviest pizza dough to the lightest whipped cream.

Construction

The W20A frame is of welded plate steel construction for strength and rigidity. All ball bearings and needle bearings are sealed to protect from foodstuff and moisture damage. Durable powder coating finish is used on those surfaces not constructed of stainless steel.

Stainless steel is extensively used in the construction of the W20A for quick clean-up and long life. The top cover, planetary cover, beater shaft, all agitator shafts, bowl, hook, whip wires, control handles, and bowl clamps are all constructed of stainless steel.

Standard Accessories

The W20A comes equipped with a timer, stainless steel 21 qt. bowl, stainless steel wire whip, stainless steel dough hook, and an alloy flat beater.

Attachment Hub

The W20J is equipped with a #12 attachment hub. The speed range for the hub is 90 to 420 rpm.

Options

- 13 qt. bowl and accessories
- Bowl scraper in 21 qt. and 13 qt. sizes
- Stainless steel wing whip
- Pastry knife
- Mixer table - with or without casters (*see pictures*)
(Dimensions 18"W x 24"D x 22"H)
- Vegetable slicer and shredder plates
- Meat grinder

Bidding Specifications

- Powerful 1 hp motor, with cord and plug in **115/60/1** electrical spec.
- Overload protection and no voltage release is standard equipment.
- #12 attachment hub with 90 to 420 rpm speed range.
- UL Listed, NSF Listed
- Neoprene feet to minimize walking, rusting or counter damage.
- Provisions for bolting to counter or table.
- Permanently lubricated planetary head and attachment hub case.



Model W20A

Dimension Data

Level Capacity of large bowl	Qt.	21
Level Capacity of small bowl	Qt.	13
Width Overall	In.	17 7/8
Depth Overall	In.	26 1/2
Height Overall	In	34 7/8

Electrical Data for Motor**

60HZ / 1 Phase		
Voltage*	V	115
Feed Wires incl. Ground	No.	3
Motor Power	HP	1
Amperes, full load	A	12

Mixing Speed

Agitator Speed	Min.	100
Agitator Speed	Max.	450
Attachment Hub	R.P.M.	90-420

Shipping Data

Basic Machine plus 1 s/s bowl, 1 set of standard tools

Measurement

Shipping Box		
Width	In.	28 1/2
Depth	In.	30 1/2
Height	In.	46 1/2
Volume	Cu.Ft.	23.4

Weight Data

Net Weight	Lbs.	196
Gross Weight	Lbs.	233

Capacity Chart

Mashed Potatoes	Whip or Beater	17 lbs.
Whipped Cream	Whip	4 Qts.
Muffins	Beater	24 lbs.
Layer Cake	Beater	23 lbs.
Pie Dough	Pastry Knife	21 lbs.
Pancake Batter	Whip or Beater	9 Qts.
Cookie Dough	Beater or Hook	14 lbs.
Donuts, Yeast	Hook	20 lbs.
Donuts, Cake	Beater	23 lbs.
Bread Dough (65% AR)	Hook	25 lbs.
Pizza Dough (50% AR)***	Hook	12 lbs.

%AR= $\frac{\text{weight of water}}{\text{weight of flour}}$

*On the nominal motor voltage + or - 10% tolerance is allowed.

**Also available in 220/60/1, 220/50/1, 110/50/1. Not submitted for UL listing.

***Varimixer also features our Model W20P, specifically designed for pizza and pretzel dough.

Specifications are subject to change without notice.

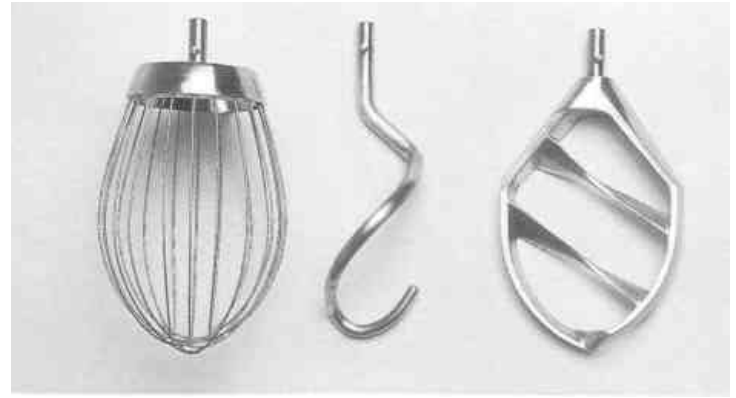

Standard tools: Whip, hook and beater.

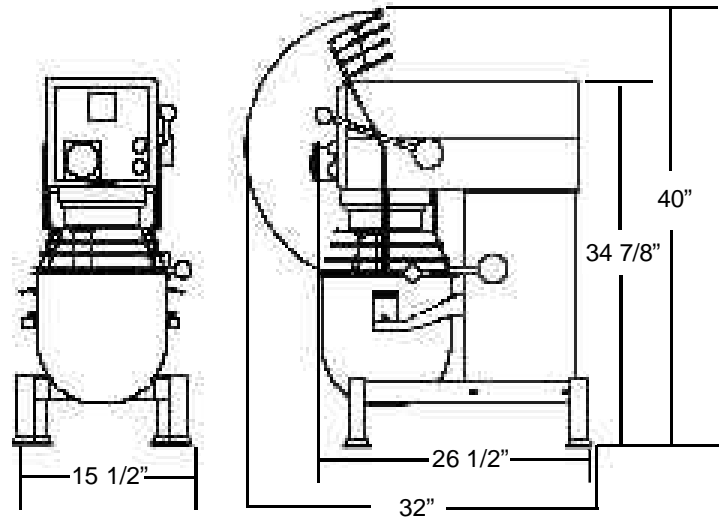

This mixer is listed by:



Varimixer



Pizzaovens.com

1.877.FOR.OVEN
367.6836

Since 1999