



# Varimixer

## HEAVY DUTY PIZZA/DOUGH- FOOD MIXER

### Model W40P



#### Mixing system

The VARIMIXER W40P planetary mixer has a heavy-duty variable speed drive system. The mixer frame consists of a column with welded-on feet, and a top traverse closed by a stainless steel cover.

The bowl is mounted in bowl arms, which raise and lock simultaneously. An oil damper compensates and smoothes lowering of the bowl. The column contains the motor and the bowl arm mechanism. The top traverse contains the transmission system consisting of moveable pulleys and the planetary head. Start and stop push buttons are mounted on a frontplate along with the contactor and the motor overload. A 15 minute electrical timer with HOLD feature is standard.

The W40P mixing tools are mounted in a dual slotted bayonet shaft. The W40P dough hook features a dual pin to assure reliability in the toughest applications.

The W40PI is a special single speed Varimixer for maximum capacity applications. The W40PI dough hook turns at 55 rpm, which is ideal for the toughest pizza and pretzel doughs.

#### Construction

Reinforced mixer frame of extra heavy-gauge, welded, rolled steel plate. Silver-gray hammertone powder coated finish. Top cover, splash apron and planetary head cap in heavy-gauge stainless steel. Molded PVC foot and kneepads. **Bowl in stainless steel.** Dough hook in stainless steel with dual drive pins. Bayonet shaft in stainless steel. **Extra powerful 3 HP motor** sitting in a reinforced flange. The planetary head revolves in heavy-duty ball and needle bearings around the main shaft. Precision milled beveled gear on the main shaft engages the bayonet shaft and the fixed internal gear ring through a double set of milled gears obtaining extra high torque capability at the dough hook.

Precision milled cast iron bowl arms lower and raise the bowl and clamp it in a precise position relative to the mixing tool allowing for small tolerances between hook and bowl. Rollers are fitted to the bowl arms to assure precise centering.

The attachment drive is directly coupled to the motor for maximum power to the meat grinder or vegetable cutter. The 198 rpm speed and the powerful motor give the accessories extra high throughput in relation to the size of the mixer.

#### Bidding Specifications

##### Standard Features

- By manually operating a single lever, the bowl raises and locks in position.
- Dual tension belt drive pulleys eliminates slippage.
- Locking pin on tool instead of shaft.
- No Bowl adaptors required for the downsize bowls.
- Bowl trucks come with a handle for easy use.
- Always the right mixing speed for the particular job with the variable speed drive.
- Unique planetary head design with very heavy duty shafts and bearings.
- Lubrication of planetary head only by permanent grease, no oil leakages into the bowl.
- Automatic stop of mixer when the bowl is lowered.
- Sanitary and easy to clean. Lip seal on planetary head prevents entrance of dust and water.
- 15 Minute Electrical Timer with HOLD feature.
- Stainless Steel Bowl Screen
- Stainless Steel Bowl and Dough Hook.

#### Optional accessories

- Mark IV programmable controls
- Small bowl with matching set of tools
- Bowl trucks
- Meat grinder
- Vegetable cutter
- Special whips
- Automatic bowl scraper
- Single Speed Transmission

# Model W40P

## Dimension Data

Level Capacity of large bowl	Qt.	42
Level Capacity of small bowl	Qt.	21
Width Overall	In.	21
Depth Overall	In.	36
Height Overall	In.	47 5/8

## Electrical Data for Motor

3 HP -- 11 amps	208/240 volt*	1 ph
3 HP -- 8 amps	208/240 volt*	3 ph

## Mixing Speed

Minimum Agitator Speed	65 R.P.M.
Maximum Agitator Speed	300 R.P.M.
Attachment Drive	198 R.P.M.
Mixing speed <b>W40PI</b>	55 R.P.M.

## Shipping Data

Basic Machine plus 1 s/s bowl, 1 S/S Hook

### Measurement

Shipping Box		
Width	In.	27
Depth	In.	42 1/2
Height	In.	57
Volume	Cu.Ft.	38

### Weight Data

Net Weight	Lbs.	392
Gross Weight	Lbs.	480

## Capacity Chart

Mashed Potatoes	Whip or Beater	30 lbs.
Whipped Cream	Whip	9 Qts.
Muffins	Beater	50 lbs.
Layer Cake	Beater	45 lbs.
Pie Dough	Pastry Knife	47 lbs.
Pancake Batter	Whip or Beater	16 Qts.
Cookie Dough	Beater or Hook	40 lbs.
Donuts, Yeast	Hook	52 lbs.
Donuts, Cake	Beater	51 lbs.
Bread Dough (65% AR)	Hook	55 lbs.
Pizza Dough (50% AR)	Hook	45 lbs.

%AR=  $\frac{\text{weight of water}}{\text{weight of flour}}$

\*On the nominal motor voltage + or - 10% tolerance is allowed.  
Specifications are subject to change without notice.

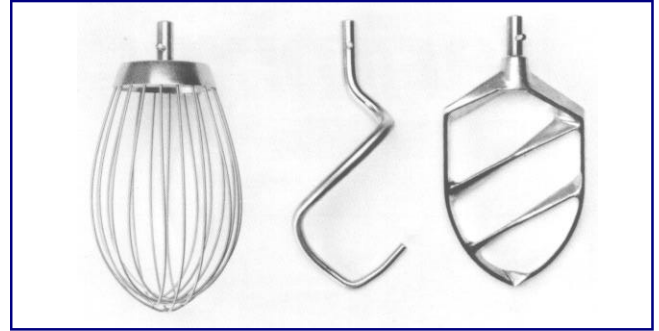

Standard tools: W40P/W40PI- S/S Hook  
W40PA- Whip, hook, beater

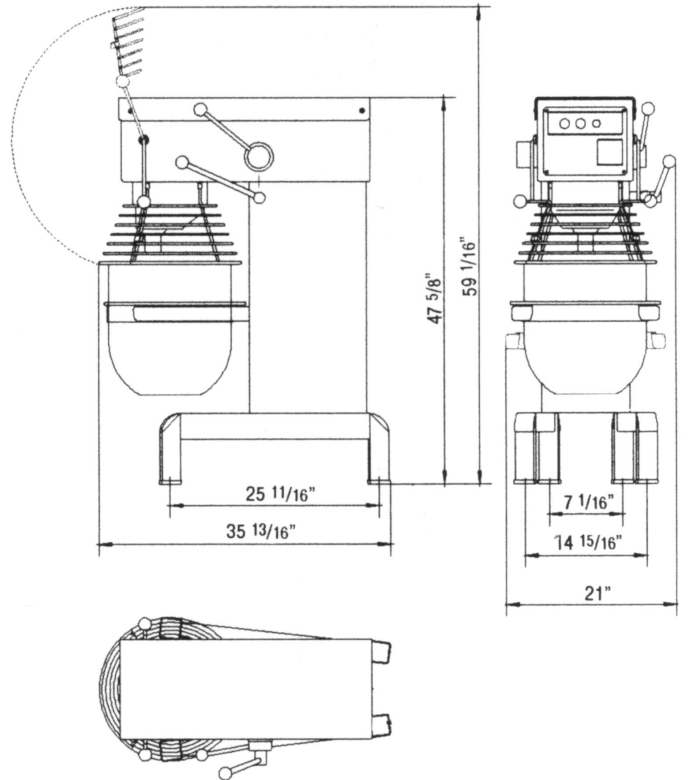

This mixer is listed by:



LISTED



Pizzaovens.com

1.877.FOR.OVEN  
367.6836

Since 1999

 **Varimixer**