



# Varimixer

## FOOD MIXER

### Model W60



#### Mixing system

VARIMIXER is a planetary mixer with a variable speed drive system. The mixer frame consists of a column with welded-on feet, and a top traverse closed by a stainless steel cover.

The bowl is mounted in bowl arms, which manually are raised and locked simultaneously - or lowered and opened, respectively. The column contains the motor and the bowl arm mechanism. The top traverse contains the transmission system consisting of the moveable pulleys, the intermediate belt drive and the planetary head. Start and stop push buttons are mounted on a front plate along with the contactor for protecting the motor against overload. A 15 minute electrical timer with HOLD feature is standard on the W60.

#### Construction

Mixer frame of extra heavy-gauge, welded, rolled steel plate. Silver-gray hammertone powder coating finish. Top cover, splash apron and planetary head cap in heavy-gauge stainless steel. Molded PVC feet pads. Bowls in stainless steel. Mixing tools in cast aluminum or stainless steel. Bayonet shaft in stainless steel. Variable speed V-belt transmission based on precision machined cast iron pulleys. Springloaded moveable pulleys in the variable speed drive for automatically adjusting of the tension of the special V-belt. Planetary mixer head of unique design. The planetary head revolves in heavy-duty ball and needle bearings around the main shaft. Precision milled beveled gear on the main shaft engages the bayonet shaft and the fixed internal gear ring through a double set of milled gears obtaining extra high torque capabilities of the mixing tools.

Precision milled cast iron bowl arms lower and raise the bowl and clamp it in a precise position relative to the mixing tool allowing for small tolerances between tool extremities and the bowl.

Attachment drive directly coupled to the motor securing maximum power output to the meat grinder or vegetable cutter. The 198-rpm high speed and the powerful motor give the meat grinder an unusually high capacity in relation to the size of the mixer.

#### Bidding Specifications

##### Standard Features

- By manually operating a single lever, the bowl raises and locks in position.
- Dual tension belt drive pulleys eliminates slippage.
- Locking pin on tool instead of shaft.
- No bowl adaptors required for the downsize bowls.
- Bowl trucks come with a handle for easy use.
- Always the right mixing speed for the particular job with the variable speed drive.
- Unique planetary head design with very heavy duty shafts and bearings.
- Lubrication of planetary head only by permanent grease, no oil leakages into the bowl.
- Automatic stop of mixer when the bowl is lowered.
- Sanitary and easy to clean. Lip seal on planetary head prevents entrance of dust and water.
- 15 Minute Electrical Timer with HOLD feature.
- Stainless Steel Bowl Screen
- Stainless Steel Bowl, wire whip, dough hook and aluminum beater.

#### Optional accessories

- Mark IV programmable controls
- Small bowl with matching set of tools
- Bowl trucks
- Meat grinder
- Vegetable cutter
- Special whips
- Automatic bowl scraper
- Single Speed Transmission
- ERGO (tall column)

# Model W60

## Dimension Data

Level Capacity of large bowl	Qt.	63
Level Capacity of small bowl	Qt.	32
Width Overall	In.	25 1/2
Depth Overall	In.	40 1/2
Height Overall	In.	55 5/8

## Electrical Data for Motor

3 HP -- 11 amps	208/240 volt*	1 ph
3 HP -- 6 amps	208/240 volt*	3 ph

## Mixing Speed

Minimum Agitator Speed	60 R.P.M.
Maximum Agitator Speed	300 R.P.M.
Attachment Drive	198 R.P.M.

## Shipping Data

Basic Machine plus 1 S/S Bowl, 1 S/S Hook, 1 S/S Wire Whip and 1 Aluminum Beater

### Measurement

Shipping Box		
Width	In.	29
Depth	In.	44
Height	In.	67
Volume	Cu.Ft.	52

### Weight Data

Net Weight	Lbs.	542
Gross Weight	Lbs.	654

## Capacity Chart

Mashed Potatoes	Whip or Beater	46 lbs.
Whipped Cream	Whip	12 Qts.
Muffins	Beater	60 lbs.
Layer Cake	Beater	69 lbs.
Pie Dough	Pastry Knife	58 lbs.
Pancake Batter	Whip or Beater	28 Qts.
Cookie Dough	Beater or Hook	50 lbs.
Donuts, Yeast	Hook	70 lbs.
Donuts, Cake	Beater	60 lbs.
Bread Dough (65% AR)	Hook	90 lbs.
Pizza Dough (50% AR)	Hook	75 lbs.

$$\% \text{ AR} = \frac{\text{weight of water}}{\text{weight of flour}}$$

\*On the nominal motor voltage + or - 10% tolerance is allowed.  
Specifications are subject to change without notice.



Standard tools: Whip, hook, beater

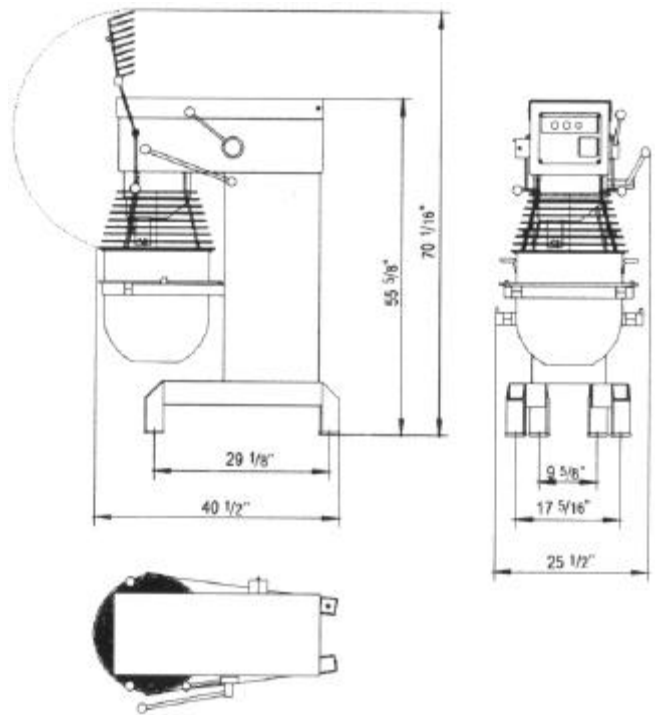

This mixer is listed by:



Pizzaovens.com

1.877.FOR.OVEN  
367.6836

Since 1999

 **Varimixer**