



# Varimixer

## HEAVY DUTY PIZZA/DOUGH- FOOD MIXER

### Model W60P



#### General Description

The new Varimixer W60P has been designed for those who want the most from their 60-quart planetary mixer — excellent mixing performance and extraordinary power. The W60P is recommended for pizza applications, heavy dough applications, and other high demand uses.

The Varimixer bowl shape and capacity along with the unique stainless steel dough hook combine to provide outstanding dough development with little or no splashout. The 4 HP drive motor and rugged drive system assure that plenty of power is available to handle the toughest recipes, batch after batch and year after year.

The W60P comes standard with thermal overload protection, no voltage release, 15 minute timer with HOLD feature, stainless steel 63 quart bowl, attachment hub and stainless steel double pin dough hook.

The unique Varimixer bowl mounting system eliminates cumbersome pins and clamps. On the W60P, a standard oil damper compensates and smoothes lowering of the bowl.

The W60P provides a full agitator speed range — lower speeds for ingredient incorporation and heavy dough preparation — higher speeds for air incorporation and whipping.

#### Construction

Reinforced mixer frame of extra heavy-gauge, welded, rolled steel plate. Silver-gray-hammertone powder coated finish. Top cover, splash apron and planetary head cap in heavy-gauge stainless steel. Molded PVC foot and knee pads. **Bowl in stainless steel.** Dough hook in stainless steel. Bayonet shaft in stainless steel. Extra powerful 4 HP motor sitting in a reinforced flange. The planetary head revolves in heavy-duty ball and needle bearings around the main shaft. Precision milled beveled gear on the main shaft engages the bayonet shaft and the fixed internal gear ring through a double set of milled gears. Obtaining extra high torque capability at the dough hook.

The **W60P** mixing tools are mounted in a dual slotted bayonet shaft. The W60P dough hook features dual drive pins to assure reliability in the toughest applications.

The **W60PI** is a special single speed Varimixer for maximum capacity applications. The W60PI dough hook turns at 55 rpm, which is ideal for the toughest pizza and pretzel doughs.

Precision milled cast iron bowl arms lower and raise the bowl and clamp it in a precise position relative to the mixing tool allowing for small tolerances between hook and bowl. Rollers are fitted to the bowl arms to assure precise centering.

#### Bidding Specifications

##### Standard Features

- By manually operating a single lever, the bowl raises and locks in position.
- Dual tension belt drive pulleys eliminates slippage.
- Locking pin on tool instead of shaft.
- No bowl adaptors required for the downsize bowls.
- Bowl trucks come with a handle for easy use.
- Always the right mixing speed for the particular job with the variable speed drive.
- Unique planetary head design with very heavy duty shafts and bearings.
- Lubrication of planetary head only by permanent grease, no oil leakages into the bowl.
- Automatic stop of mixer when the bowl is lowered.
- Sanitary and easy to clean. Lip seal on planetary head prevents entrance of dust and water.
- 15 Minute Electrical Timer with HOLD feature.
- Stainless Steel Bowl Screen
- Stainless Steel Bowl and dough hook.

#### Optional accessories

- Mark IV programmable controls
- Small bowl with matching set of tools
- Bowl trucks
- Meat grinder
- Vegetable cutter
- Special whips
- Automatic bowl scraper
- Single Speed Transmission
- ERGO (tall column)

# Model W60P

## Dimension Data

Level Capacity of large bowl	Qt.	63
Level Capacity of small bowl	Qt.	32
Width Overall	In.	25 1/2
Depth Overall	In.	40 1/2
Height Overall	In.	55 5/8

## Electrical Data for Motor

4 HP -- 12.7 amps	208/240 volt*	3 ph
3 HP -- 8 amps	208/240 volt*	1 ph

## Mixing Speed

Minimum Agitator Speed	60 R.P.M.
Maximum Agitator Speed	300 R.P.M.
Attachment Drive	198 R.P.M.
Mixing speed <b>W60PI</b>	55 R.P.M.

## Shipping Data

Basic Machine plus 1 S/S bowl, 1 S/S Hook

### Measurement

Shipping Box		
Width	In.	29
Depth	In.	44
Height	In.	67
Volume	Cu.Ft.	52

### Weight Data

Net Weight	Lbs.	542
Gross Weight	Lbs.	654

## Capacity Chart

Mashed Potatoes	Whip or Beater	46 lbs.
Whipped Cream	Whip	12 Qts.
Muffins	Beater	60 lbs.
Layer Cake	Beater	69 lbs.
Pie Dough	Pastry Knife	58 lbs.
Pancake Batter	Whip or Beater	28 Qts.
Cookie Dough	Beater or Hook	58 lbs.
Donuts, Yeast	Hook	75 lbs.
Donuts, Cake	Beater	60 lbs.
Bread Dough (40% AR)	Hook	90 lbs.
Pizza Dough (50% AR)	Hook	75 lbs.

$$\% \text{ AR} = \frac{\text{weight of water}}{\text{weight of flour}}$$

\*On the nominal motor voltage + or - 10% tolerance is allowed.  
Specifications are subject to change without notice.

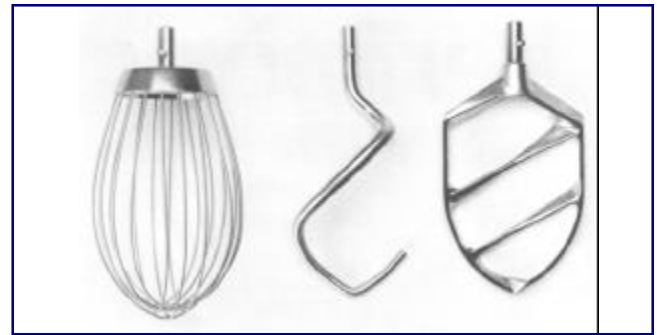

Standard tools: W60P/W60PI- S/S Hook  
W60PA- Whip, hook, beater

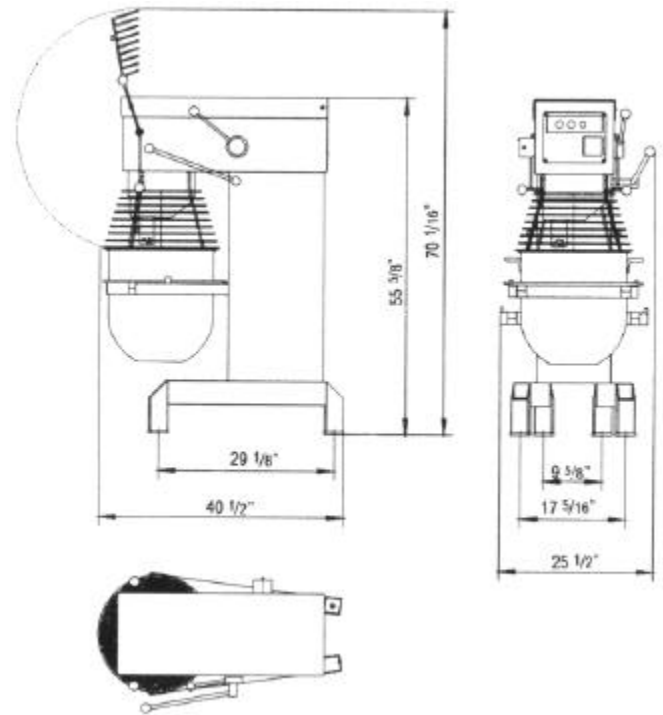

This mixer is listed by:



Pizzaovens.com

1.877.FOR.OVEN  
367.6836

Since 1999

**Varimixer**