



GT-60

Refrigeration systems feature low maintenance bare tube condenser coils.



## GT SERIES

### Low Temp Horizontal Display Merchandisers

#### MODELS

- GT-30
- GT-40
- GT-50
- GT-60
- GT-80

## FEATURES

#### CONSTRUCTION

- 24 gauge painted steel interior and exterior
- Flat, 18" laminated white formica counter top
- Mirrored finish stainless steel light shield
- Anodized aluminum trim with black vinyl bumpers
- Protective front bumper
- Automatic condensate evaporator
- Fluorescent lighting with independent on/off switch
- Front air discharge and intake
- Easily convertible to rear air discharge
- Independent on/off power switch
- 2" Foamed-in-place "zero ODP" urethane insulation

#### FINISH

- Sparkling white polyester enamel interior and exterior

#### LIDS

- Heat reflective lids with tempered glass
- Self-closing with hold-open feature for stocking

#### REFRIGERATION

- Self-contained, slide-out semi-hermetic condensing unit
- Cold wall and gravity coil evaporator
- Refrigerant: R-404A
- Temperature range: 0° to -20°F (-18° to -29°C)
- R-factor (insulation efficiency rating): 17.24

#### WARRANTY

- Standard limited four year extended compressor and one year limited parts and labor

## OPTIONS

- Custom colors
- Baskets
- Load level shelves
- Lighted two-shelf superstructure
- Lid locking kits (less locks)
- Sack rack
- Casters



# GT SERIES

## LOW TEMP HORIZONTAL DISPLAY MERCHANDISERS

### TECHNICAL SPECIFICATIONS

MODEL	DIMENSIONS (in.)			DIMENSIONS (mm)			VOLTS	AMPS	UNIT H.P.	NO. OF LIDS	CAP. CU. FT.	SHIP CU. FT.	SHIP WT. LB/KG
	L	D	H	L	D	H							
GT-30	36 <sup>15</sup> / <sub>16</sub>	32 <sup>3</sup> / <sub>16</sub>	39 <sup>3</sup> / <sub>8</sub>	938	864	1000	115	9.9	1/2	1	7.2	43.0	435/198
GT-40	48 <sup>5</sup> / <sub>8</sub>	32 <sup>3</sup> / <sub>16</sub>	39 <sup>3</sup> / <sub>8</sub>	1235	864	1000	115	9.9	1/2	2	10.0	50.0	470/214
GT-50	60 <sup>3</sup> / <sub>8</sub>	32 <sup>3</sup> / <sub>16</sub>	39 <sup>3</sup> / <sub>8</sub>	1533	864	1000	115	10.1	3/4	2	13.5	60.0	530/241
GT-60	72 <sup>5</sup> / <sub>16</sub>	32 <sup>3</sup> / <sub>16</sub>	39 <sup>3</sup> / <sub>8</sub>	1837	864	1000	115	10.3	3/4	2	17.4	71.0	585/266
GT-80	95 <sup>15</sup> / <sub>16</sub>	32 <sup>3</sup> / <sub>16</sub>	39 <sup>3</sup> / <sub>8</sub>	2437	864	1000	115	12.0	3/4	3	25.5	92.0	705/320

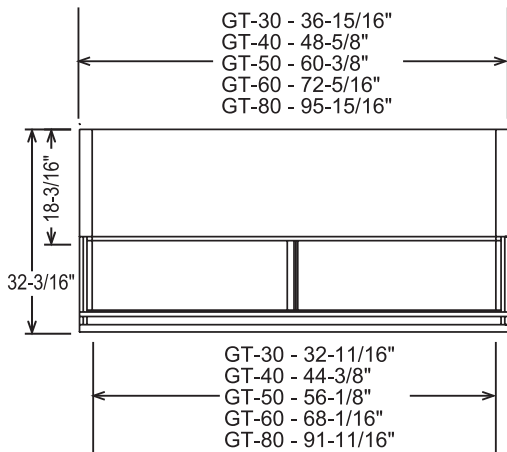

PLAN VIEW

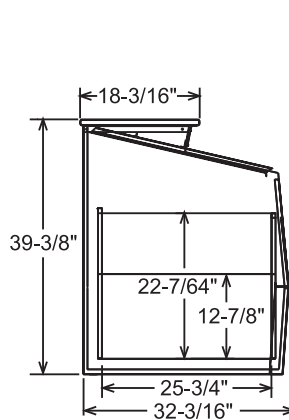

SIDE VIEW

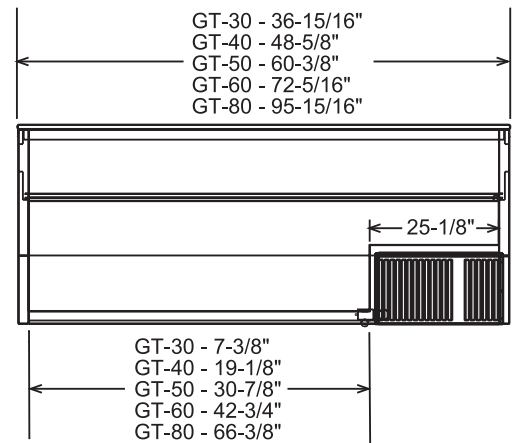

ELEVATION VIEW

### LISTINGS



### HOOKUP

Via plug in, 9 foot long, flexible 3 wire 14/3 cord with molded plug.



### BID SPECIFICATIONS

Item no. GT-\_\_\_\_\_

Provide \_\_\_\_\_ ( )

Low Temp Horizontal Display Merchandiser(s), Master-Bilt model no. GT-\_\_\_\_\_.

Merchandiser to have tempered, heat reflective glass lids with self-closing and hold-open features, mirrored finish stainless steel light shield, protective front bumper and front air discharge compressor

compartment.

The refrigeration system will contain a self-contained, slide out semi-hermetic compressor, automatic condensate evaporator and have cold wall and gravity coil evaporator. Additionally, merchandiser is to feature a low maintenance bare tube condenser coil. The temperature range will be 0° to -20°F (-18° to -29°C).

Merchandiser to have standard limited

four year extended compressor warranty and one year limited parts and labor warranty. Merchandiser to be UL, C-UL and NSF listed.

**NOTE:** Cabinet designed for optimum performance in air-conditioned area at 75°F ambient and 55% relative humidity. All specifications subject to change without notice.

