



IM-23GB



IM-23GB SERIES

Indoor Ice Merchandiser

MODEL

- ☐ IM-23GB

FEATURES

STANDARD ELECTRONIC CONTROL

- Tamper proof control
- Allows user to monitor and adjust temperature set point within normal temperature range
- Visual alarm
- Decreases service time and calls
- Eliminates room thermostat, defrost termination/fan delay control, defrost timer and digital thermometer or other temperature indicator



CONSTRUCTION

- Two-inch thick foamed-in-place "zero ODP" urethane insulation
- Interior fluorescent light
- Adjustable leveling legs
- Compressor on/off switch
- Rear wall guard for efficient air circulation
- Heavy-duty welded wire bottom shelf

FINISH

- Sparkling white polyester enamel interior and exterior

DOOR

- Auto-close, triple pane glass door with hold-open feature
- Door size: 24¹/₂" x 61¹/₈"
- White door frame
- Replaceable gaskets
- "Bagged Ice" decal affixed to door front

REFRIGERATION

- Refrigerant: R-134A
- Self-contained, bottom mounted, factory tested refrigeration system
- Slide-out system for easy access
- Top mounted, low profile interior fan housing
- Temperature range: 20° to 25°F (-7° to -4°C)
- R-factor (insulation efficiency rating): 17.24

WARRANTY

- Standard limited four year extended compressor and one year limited parts and labor



IM-23GB SERIES INDOOR ICE MERCHANDISER

TECHNICAL SPECIFICATIONS

MODEL	DIMENSIONS (in.)			DIMENSIONS (mm)			VOLTS	AMPS	UNIT H.P.	CAPACITY 8 LB. BAGS	SHIP CU. FT.	SHIP WT. (LB/KG)
	L	D	H	L	D	H						
IM-23GB	27	36 ¹ / ₈	79	686	918	2007	115	8.0	1/3	60	79.0	360/164

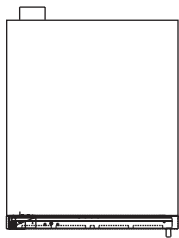

PLAN VIEW

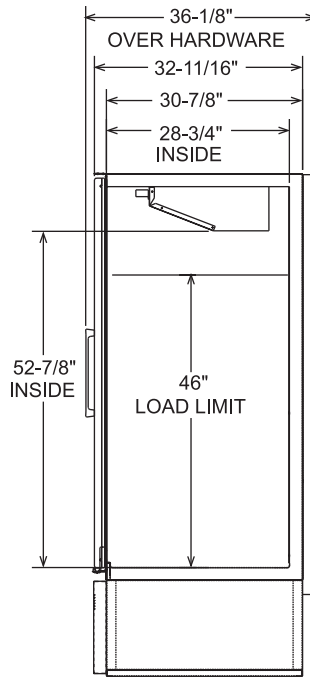

SIDE VIEW

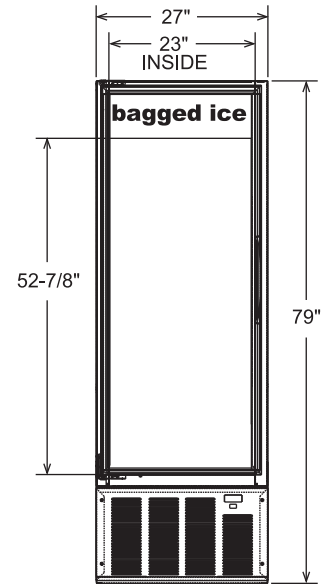

ELEVATION VIEW

LISTINGS



HOOKUP

Via plug in, 9 foot long, flexible three wire 14/3 cord with molded plug.



BID SPECIFICATIONS

Item no. IM-23GB

Provide _____ ()

Indoor Ice Merchandiser(s), Master-Bilt model no. IM-23GB.

Merchandiser to be provided with an electronically controlled monitoring system.

Construction features include two-inch thick foamed-in-place "zero ODP" urethane insulation, interior fluorescent light,

adjustable leveling legs, independent compressor on/off switch, a rear wall guard for efficient air circulation and a heavy-duty welded wire bottom shelf.

Merchandiser door will contain triple pane glass and will auto-close. Door will also have a hold-open feature.

The refrigeration system is to have a self-contained, bottom mounted condensing

unit with R-134A refrigerant. Condensing unit will also slide out for easy access. The temperature range is to be 20° to 25°F (-7° to -4°C).

Merchandiser to have standard limited four year extended compressor warranty and one year limited parts and labor warranty. Merchandiser to be UL and C-UL listed and UL EPH classified.

NOTE: Cabinet designed for optimum performance in air-conditioned area at 75°F ambient and 55% relative humidity. All specifications subject to change without notice.

