



OMC-122



## OMC SERIES

### Cold Wall Evaporator Open Front Milk Coolers

#### MODELS

- OMC-082
- OMC-122
- OMC-162

## FEATURES

#### CONSTRUCTION

- White enamel painted steel exterior
- Galvanized steel interior including door interior
- Four 4" easy-roll swivel casters (two locking)
- Epoxy-coated heavy-duty floor racks (stainless steel option available)
- Reinforced base to maintain cooler integrity when fully loaded
- 2 1/2" fiberglass insulation
- NSF-listed floor drain
- NSF-listed thermometer

#### DOOR

- Self service doors with stainless steel exterior
- Fold-back door is locking and insulated
- Door equipped with gaskets and chrome plated hinges
- Designed to be easily opened by children for self-service

#### REFRIGERATION

- Self-contained, bottom mount
- Powerful, large-capacity system allows cooler to maintain proper temperature for longer amount of time with doors open

- Cold wall evaporator with no moving parts which allows more storage space
- Refrigerant: R-22
- Operating temperature: 38°F (3°C)

#### WARRANTY

- Standard limited four year extended compressor and one year limited parts and labor

## CAPACITY

MODEL	CASES WITH CARTONS				LOOSE CARTON (WITHOUT CASES)	
	13" x 13" x 11"H		19" x 13" x 11"H		1/2 PINT	1 PINT
	CASES	CARTONS	CASES	CARTONS		
OMC-082	8	352	4	288	864	432
OMC-122	12	528	8	576	1368	684
OMC-162	16	704	12	864	1800	900

## OPTIONS

- Add "SS" for stainless steel interior and exterior
- Laminate for top, front, sides and back
- (4) six-inch adjustable legs
- Strip curtain
- Stainless steel floor rack
- Corner bumpers



# OMC SERIES

## COLD WALL EVAPORATOR OPEN FRONT MILK COOLERS

### TECHNICAL SPECIFICATIONS

MODEL	DIMENSIONS (in.)			DIMENSIONS (mm)			VOLTS	AMPS	UNIT H.P.	NO. OF FLOOR RACKS	CAP. CU. FT.	SHIP CU. FT.	SHIP WT. LB/KG
	L	D	H*	L	D	H*							
OMC-082	35	34	44	889	864	1118	115	5.0	1/5	2	12.2	36.7	326/148
OMC-122	49	34	44	1245	864	1118	115	5.0	1/5	3	17.8	49.9	352/160
OMC-162	63	34	44	1600	864	1118	115	5.0	1/5	4	23.5	64.0	484/220

\*Height includes casters.

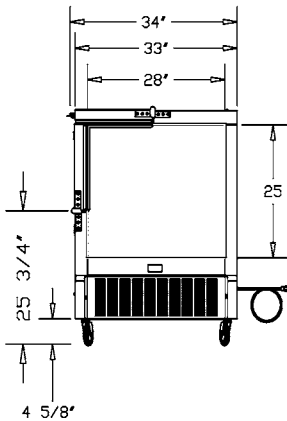

SIDE VIEW

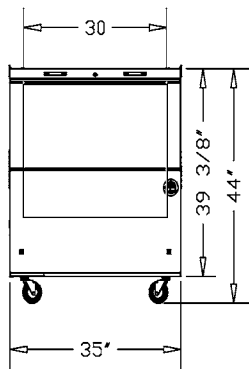

OMC-082 ELEVATION VIEW

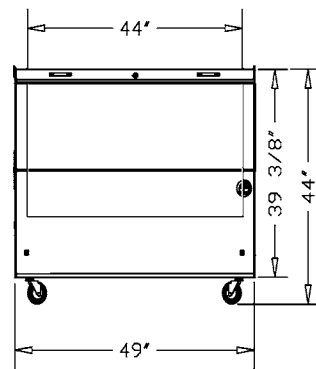

OMC-122 ELEVATION VIEW

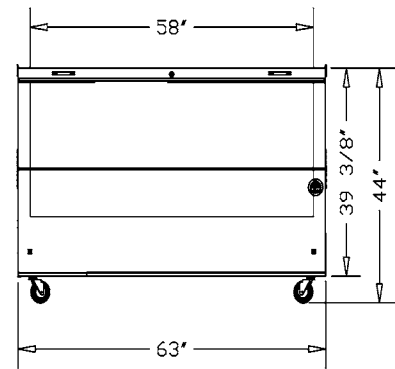

OMC-162 ELEVATION VIEW

### LISTINGS



### HOOKUP

Via plug in, 7 foot long flexible three wire 16 gauge cord with molded plug.



### BID SPECIFICATIONS

Item no. OMC- \_\_\_\_\_  
 Provide \_\_\_\_\_ ( ) Cold Wall Evaporator Open Front Milk Cooler(s), Master-Bilt model no. OMC-\_\_\_\_.  
 Milk cooler to be constructed of white painted steel on the exterior with galvanized steel interior. Door to be stainless steel on the exterior with galvanized steel interior. Door will also be a fold-back type and will be locking and insulated. In ad-

dition, door will be equipped with gaskets and chrome plated hinges.  
 Cooler to be provided with four swivel casters (two locking) and an NSF-listed floor drain and thermometer. Additionally, cooler will contain heavy-duty epoxy-coated floor racks and a reinforced base to maintain cooler integrity when fully loaded. Insulation will consist of 2 1/2" thick fiberglass.

The refrigeration system will be self-contained, bottom mounted with a cold wall evaporator. System will contain R-22 refrigerant. The operating temperature will be 38°F (3°C).  
 Cooler to have standard limited four year extended compressor warranty and one year limited parts and labor warranty.  
 Cooler to be UL and C-UL listed as well as UL EPH classified.

**NOTE:** Cabinet designed for optimum performance in air-conditioned area at 75°F ambient and 55% relative humidity. All specifications subject to change without notice.



Pizzaovens.com

1.877.FOR.OVEN  
367.6836

Since 1999