



Standard cord and plug on QMVM-36 and QMVM-48 models

QMVM-48

QMVM SERIES

Quantum Series Medium Temp Vertical Open Display Merchandisers

MODELS

- QMVM-36
- QMVM-48
- QMVM-72

FEATURES

STANDARD ELECTRONIC CONTROL

- Allows user to easily monitor defrost functions from the panel interface on the front of the merchandiser
- Audible and visual alarm
- Decreases service time and calls
- Eliminates room thermostat, defrost termination/fan delay control, defrost timer and digital thermometer or other temperature indicator

CONSTRUCTION

- 24 gauge galvanized steel exterior and interior
- 2" foamed-in-place "zero ODP" urethane insulation
- Shelves adjustable in 1" increments
- Three lighted tiers of two-position shelving with price tag molding
- Perforated interior back wall and top for better air flow

- Electric defrost
- Easily accessible electrical enclosure

FINISH

- White enamel interior and exterior
- Stainless steel floor pans (removable for easy service)

REFRIGERATION

- Refrigerant: R-404A
- Front air intake and rear air discharge
- Self-contained, bottom mount refrigeration system
- Temp. range: 34° to 41°F (1° to 5°C)
- R-factor (insulation efficiency rating): 17.24
- **Drain plumbing hookup recommended. Condensate pan available if there is no access to drain plumbing. Condensate pan must be field installed and requires a dedicated 15 amp, 120 volt circuit.**

WARRANTY

- Standard limited four year extended compressor and one year limited parts and labor

OPTIONS

- Add suffix "R" for remote system (QMVM-48 and -72 only)
- Add suffix "ESS" for stainless steel interior and exterior
- Custom exterior colors
- Condensate evaporator drain pan
NOTE: Must be field installed and requires a dedicated 15A, 120v circuit.
- Condensate pump
- Product hooks
- Casters
- Extra lighted shelves (one only)
- Extra non-lighted shelves
- 1" vinyl bumper in choice of black, blue, brown, green, red or white
- Vinyl retractable night curtain
- Locking metal night curtain (less locks)



QMVM SERIES

QUANTUM SERIES MEDIUM TEMP VERTICAL OPEN DISPLAY MERCHANDISERS

TECHNICAL SPECIFICATIONS

MODEL	DIMENSIONS (in.)			DIMENSIONS (mm)			VOLTS	AMPS*	UNIT H.P.	NO. OF SHELVES	STANDARD SHELF WIDTH (in inches)	CAP. CU. FT.	SHIP CU. FT.	SHIP WT. LB/KG
	L	D	H	L	D	H								
QMVM-36	36	30	81	914	762	2057	208-230	13.5	1	3	14 x 31 ¹ / ₈	13.6	89.0	525/239
QMVM-48	48	30	81	1219	762	2057	208-230	16.1	1	3	14 x 43 ¹ / ₈	20.4	107.0	640/291
QMVM-72	72	30	81	1829	762	2057	115/208-230	3.7/13.7	1 ¹ / ₂	6	14 x 33 ¹ / ₁₆	31.5	152.0	860/391

*If condensate evaporator pan accessory is used, it must be field installed and requires a dedicated 15 amp, 120 volt circuit.

Note: 208-230/60/1 also requires neutral and safety ground wire.

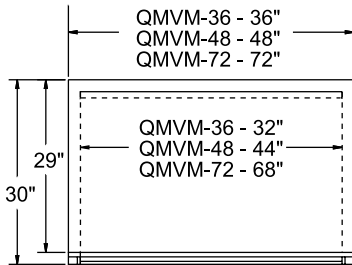

PLAN VIEW

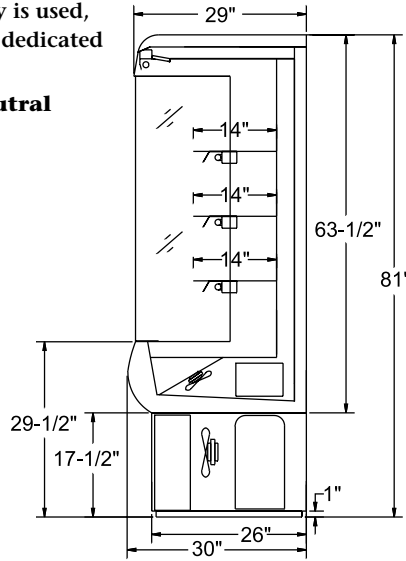

SIDE VIEW

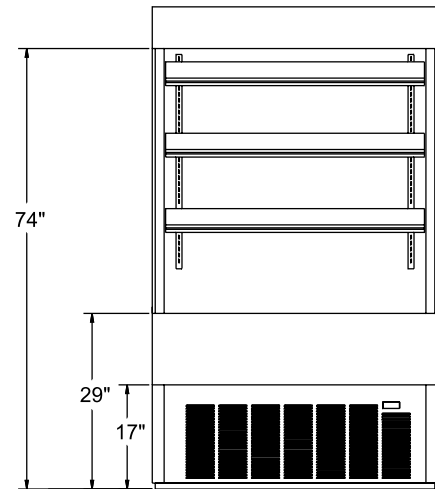

ELEVATION VIEW

LISTINGS



HOOKUP

Electrical: QMVM-36 and QMVM-48 via plug in, 9 foot long flexible four wire 208-230v 14/4 cord with neutral and ground wires and molded plug. QMVM-72 is a hardwire.

Plumbing: Requires connection to customer's drain

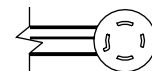

NEMA L14-20P (QMVM-36 & QMVM-48)

RECOMMENDED OPERATING CONDITIONS

- Merchandisers designed to hold product in the 34° to 41°F (1° to 5°C) range
- Designed to operate in air-conditioned stores where the maximum temperature is 75°F and the maximum relative humidity is 55%
- Should not be installed in direct sunlight
- Should not be installed near HVAC vents, fans or doorways that will disrupt airflow and compromise the function of the air screen inside the case
- Bottom shelf should not be loaded such that the front air intake is obstructed
- Floor drain should be properly trapped
- Factory installed controls should not be altered, removed or replaced without consent of the factory
- Product must not be displayed in the cold air curtain

BID SPECIFICATIONS

Item no. QMVM-_____
Provide _____ () Quantum Series Medium Temp Vertical Open Display Merchandiser(s), Master-Bilt model no. QMVM-_____.

Merchandiser to have standard electronic controller eliminating the need for a room thermostat, defrost termination/fan delay control, defrost timer and digital thermom-

eter or other temperature indicator.

Other features will include adjustable two-position shelves, independent shelf lighting, perforated interior back wall, electric defrost and 2" foamed-in-place "zero ODP" urethane insulation.

The refrigeration system is to be self-contained, have a front condenser air intake and rear air discharge and use R-404A refrigerant.

The temperature range will be 34° to 41°F (1° to 5°C).

Merchandiser to have standard limited four year extended compressor warranty and one year limited parts and labor warranty.

Merchandiser to be UL and C-UL listed and UL EPH classified.



All specifications subject to change without notice.