

SMC-122



SMC SERIES

Slide Top Milk Coolers

**Available on a special order basis.
Contact factory for details.**

MODELS

- SMC-122
- SMC-162

FEATURES

CONSTRUCTION

- Top slide doors with stainless steel exterior
- White enamel painted steel exterior
- Galvanized steel interior including door interior
- Four 4" easy-roll swivel casters (two locking)
- Heavy-duty floor racks
- Reinforced base to maintain cooler integrity when fully loaded
- 2½" fiberglass insulation
- NSF-listed drain
- NSF-listed thermometer

REFRIGERATION

- Self-contained, bottom mount
- Powerful, large-capacity system allows cooler to maintain proper temperature for longer amount of time with doors open
- Cold wall evaporator with no moving parts which allows more storage space
- Refrigerant: R-22
- Operating temperature: 38°F (3°C)

WARRANTY

- Standard limited four year extended compressor and one year limited parts and labor

CAPACITY

MODEL	CASES WITH CARTONS				LOOSE CARTON (WITHOUT CASES)	
	13" x 13" x 11"H		19" x 13" x 11"H		1/2 PINT	1 PINT
	CASES	CARTONS	CASES	CARTONS		
SMC-122	12	528	8	576	1296	649
SMC-162	16	704	12	864	1800	900

OPTIONS

- Add "SS" for stainless steel interior and exterior
- Locking bar
- (4) six-inch adjustable legs



SMC SERIES SLIDE TOP MILK COOLERS

TECHNICAL SPECIFICATIONS

MODEL	DIMENSIONS (in.)			DIMENSIONS (mm)			VOLTS	AMPS	UNIT H.P.	NO. OF FLOOR RACKS	CAP. CU. FT.	SHIP CU. FT.	SHIP WT. LB/KG
	L	D	H*	L	D	H*							
SMC-122	48	33 ¹ / ₂	43	1219	851	1092	115	5.0	1/5	3	16.0	46.3	378/172
SMC-162	63	33 ¹ / ₂	43	1600	851	1092	115	5.0	1/5	4	22.0	59.9	400/182

*Height includes casters.

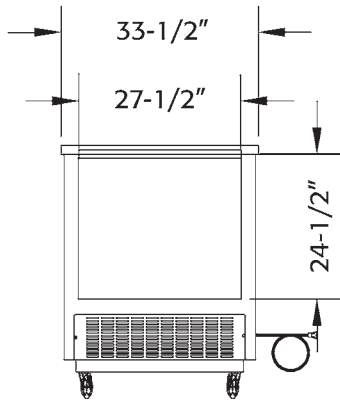

SIDE VIEW

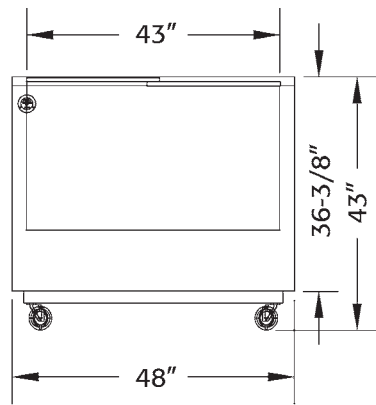

SMC-122
ELEVATION VIEW

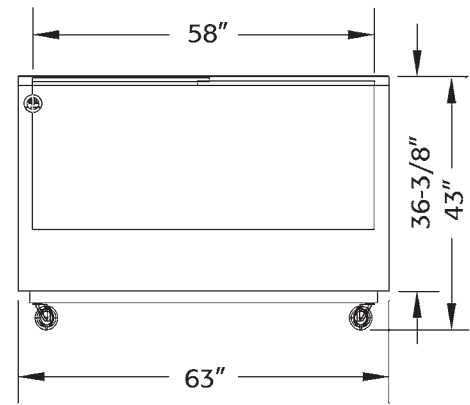

SMC-162
ELEVATION VIEW

LISTINGS



HOOKUP

Via plug in, 7 foot long flexible three wire 16 gauge cord with molded plug.



BID SPECIFICATIONS

Item no. SMC- _____
Provide _____ ()
Slide Top Milk Cooler(s), Master-Bilt
model no. SMC- _____ .

Milk cooler to be constructed of white enamel painted steel on the exterior with galvanized steel interior. Top sliding doors to be stainless steel on the exterior with galvanized steel interior. Cooler to be provided with four swivel casters (two

locking) and an NSF-listed floor drain and thermometer. Additionally, cooler will contain heavy-duty epoxy-coated floor racks and a reinforced base to maintain cooler integrity when fully loaded. Insulation will consist of 2¹/₂" thick fiberglass.

The refrigeration system will be self-contained, bottom mounted with a cold wall evaporator. System will contain R-22 refrigerant. The operating temperature

will be 38°F (3°C).

Cooler to have standard limited four year extended compressor warranty and one year limited parts and labor warranty.

Cooler to be UL and C-UL listed as well as UL EPH classified.

NOTE: Cabinet designed for optimum performance in air-conditioned area at 75°F ambient and 55% relative humidity. All specifications subject to change without notice.



Pizzaovens.com

1.877.FOR.OVEN
367.6836

Since 1999