

Model P46S

Buy this Oven at <http://Pizzaovens.com>



Model P46S

SPECIFICATIONS

The P46S Combination Bake & Roast / Pizza electric counter top ovens feature two independent, operator controlled baking chambers and Corderite hearth decks.

The P46S Combination Oven features a lower chamber with a 7 1/2" deck height for baking & roasting while the upper chamber has two hearth decks with 3 1/4" deck heights for pizza, pretzels and flat breads.

Controls for the P46S feature one set of controls for the lower chamber with a 60-minute electric timer and a 150-550° F (65-288°C) thermostat and another set of controls for the upper chamber with a 15-minute timer and a 300-650° F (149-343°C) thermostat.

The exterior front, sides, top and door are fabricated of heavy gauge type 430 stainless steel with a #4 finish. Door handle is constructed of tubular stainless steel. Exteriors measures 26" wide (660mm) by 28" deep (711mm) by 28 1/2" tall (724mm) overall.

The interiors are constructed of high heat aluminized steel, welded to form a single unitized body. The entire oven is insulated with 1 1/2" thick (38mm) industrial grade insulation. Each Corderite hearth deck measures 20 3/4" (527mm) by 20 3/4" (527mm).

Incoly, tubular heating elements provide top and bottom heat with up to 5750 watts in 208V or 220-240V, single or three phase. International voltages available. Ovens are stackable.

1 Year limited parts and labor warranty included.

STANDARD FEATURES

- P46S @ 5750 watts in 208V or 220-240V
- Two independent, operator controlled cook/bake chambers each with a separate set of controls
- Electric timers with continuous ring, audible alarms and manual shut-offs
- 150°-550°F Temperature range (65°-288°C) in the lower chamber with one 60-minute electronic minute timer
- 300-650°F Temperature range (149-343°C) in the upper chamber with a 15-minute electric timer
- Corderite hearth decks
- 7 1/2" Deck height (190mm) in lower chamber and (2) 3 1/4" deck heights (82mm) in upper chamber
- All stainless steel exterior
- Unitized, welded, aluminized steel interior
- Fully insulated
- 6' Cord and plug (1830mm)
- Limited one year parts & labor warranty

OPTIONS & ACCESSORIES

- 4" (102 mm) adjustable legs
- Stainless steel stand with or without casters
- Stacking kit
- Steel decks in lieu of Corderite
- Wire rack for center shelf of lower chamber
- Glass windows for doors
- Interior lights
- International voltages
- 250° F (121°C) Thermostat



CERTIFICATIONS



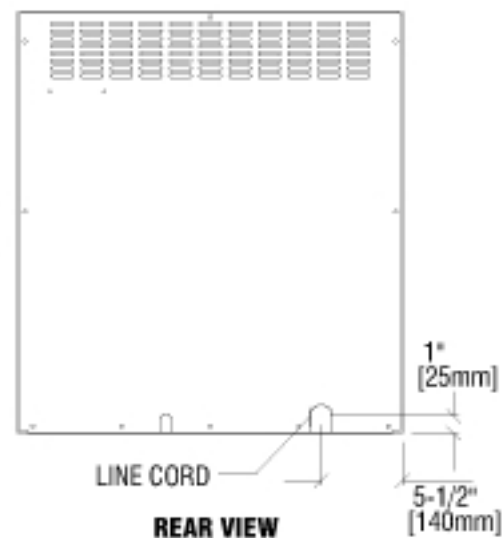
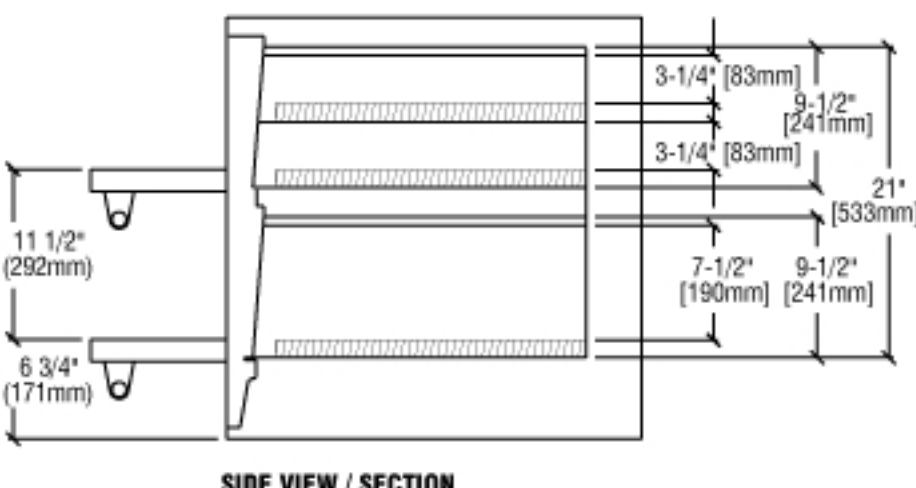
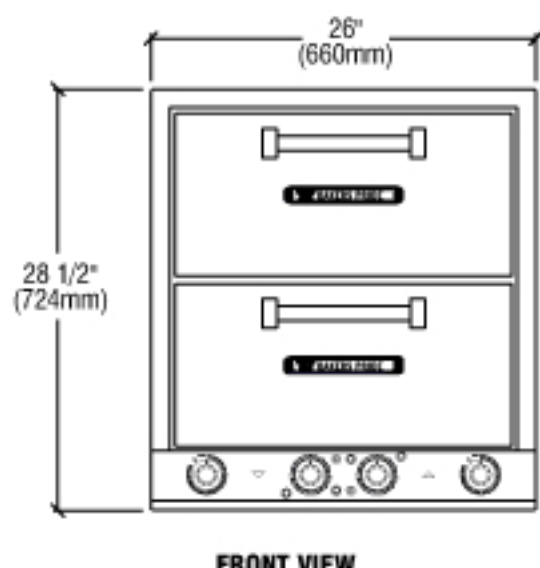
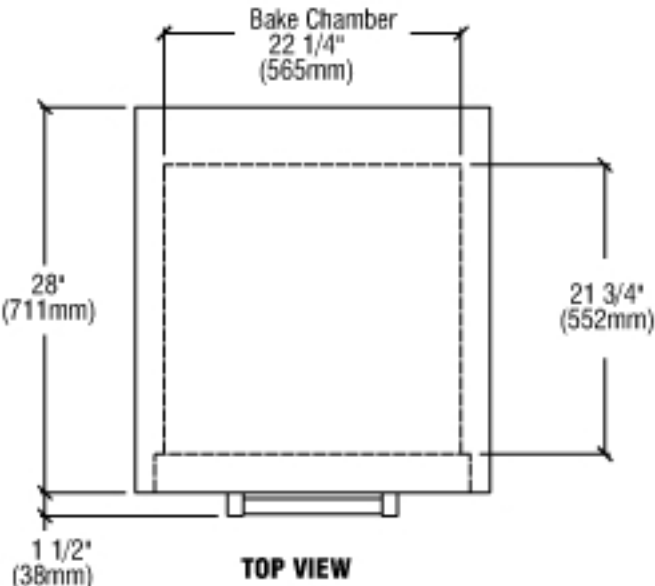

ALL DIMENSIONS NOMINAL

Model	Shipping Weight		Carton Dimensions				Carton Size			
	Lbs.	Kilos	Width Inches	Depth Inches	Height Inches	Cable Feet	Cable Meter			
P46S	309	140	30	762	32	813	32	813	17.7	.51

Under 500 lbs. = Shipping Class # 70

Model	WATS	VOLTAGE	PHASE	AMPS	SINUS Plug #	
					USA	Canada / EU
P46S	5750	208	1 & 3	27.6 & 20.3	6-30P	6-50P
P46S	5750	220-240	1 & 3	25.0 & 18.7		

Each oven requires a separate electrical connection.
 1. Please read and observe the local code and plug.
 2. Please read and observe the local voltage and the line cord.

Model	Deck Size		# Decks	# Cook Chambers	Overall Dimensions					
	Inches	mm			Width Inches	Depth Inches	Height Inches	mm		
P46S	20 3/4 x 20 3/4	527x527	3	2	26	660	28	711	28 1/2	724

	Non-Combustible Construction*		Combustible Construction**	
	Inches	mm	Inches	mm
Left Side	3	76	3	76
Right Side	3	76	3	76
Rear	3	76	3	76

* In European Community Countries and North America, in NON-COMBUSTIBLE locations only.
 ** In European Community Countries only in COMBUSTIBLE locations. NOT for North America.



Restaurant Equipment Worldwide
Toll Free: 877.FOR.OVEN
International: +1 859.885.1988



Continuous product improvement is a policy of Bakers Pride Oven Company. Therefore, specifications and design are subject to change without notification.