



ITEM NO.

MODEL NO.

81200-02 6/97
Printed in U.S.A.

“ACCU-TEMP”

Full-Size ELECTRIC CONVECTION OVEN

Thermostatically Controlled

- The thermostatically controlled Accu-Temp Electric Convection Oven accurately senses temperature, giving an even and consistent bake.
- Two-speed and Pulse Fan Features as standard. With the Pulse Fan feature, the fan only comes on when the oven calls for heat, keeping delicate food products safe.
- Standard exterior finish stainless steel.
- Each oven is available in “dual voltage” for installation on site to either 208-volt or 240-volt power, single or three phase.
- The oven is provided with an automatic interlock door switch, which turns the fan motor off when the doors are opened.
- The oven is U.L. listed and N.S.F. certified.
- Standard warranty shall cover parts and labor for one full year.

**Lifetime warranty
on full-size oven doors!**

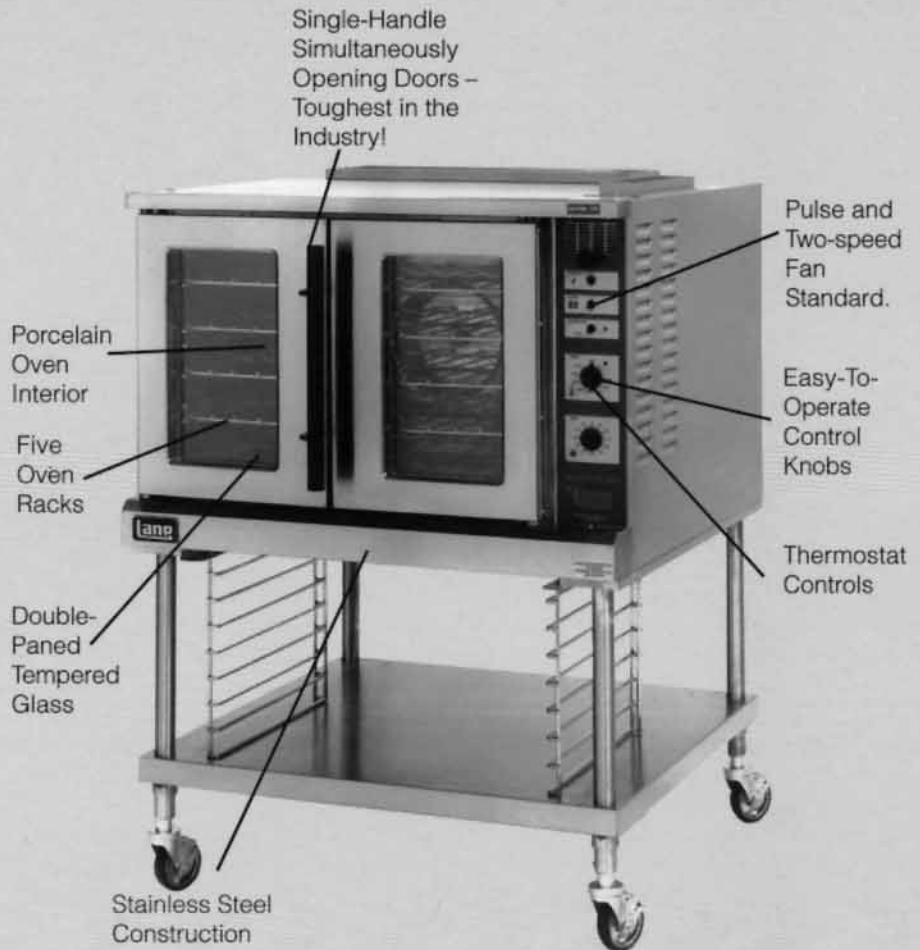

MODEL ECCO-T
ON TSC-27RS STAND
(OPTIONAL EXTRA)

ALSO AVAILABLE IN GAS
STANDARD AND EXTRA
DEEP SIZES AND
DOUBLE-STACK UNITS.

LANG MANUFACTURING COMPANY

6500 Merrill Creek Parkway
Everett, WA 98203
TOLL FREE (800) 882-6368
PHONE (425) 349-2400
SERVICE (800) 224-5264
FAX (425) 349-2733

Specifications subject to change without notice.





SPECIFICATIONS FOR ELECTRIC "ACCU-TEMP" CONVECTION OVEN

PLAN VIEW

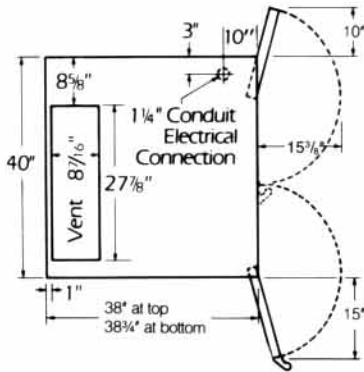

SIDE VIEW

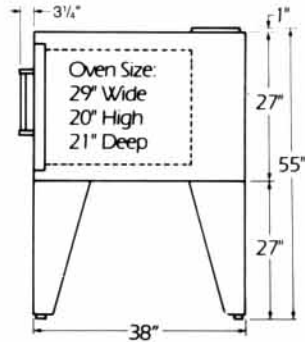

ECCO-T on Fabricated 27" legs

FRONT VIEW

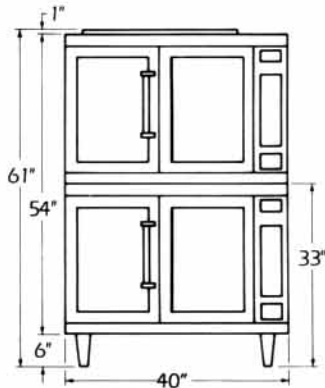

2ECCO-T

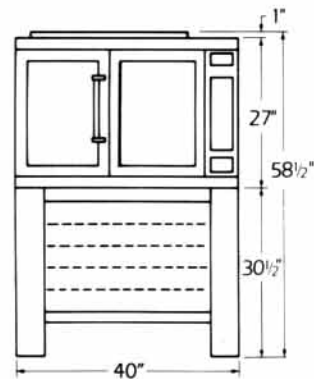

ECCO-T on Fabricated Rack-Holder Base (LS-F11RS)

SPACING REQUIREMENTS: 2" from sides & back, 6" from floor.

MODEL NUMBER	TOTAL K.W. CONNECTION	NOMINAL AMPS PER LINE									SINGLE PHASE		SHIPPING WEIGHT
		THREE PHASE									208 V	240 V	
		208 VOLT			240 VOLT			480 VOLT					
		L1	L2	L3	L1	L2	L3	L1	L2	L3			
ECCO-T	11.66	37.0	37.0	22.9	28.9	28.9	26.5	16.5	16.5	10.2	56.0	48.6	430 lbs.
2ECCO-T	23.33	60.0	74.2	60.0	55.3	57.7	55.3	26.0	33.0	26.0	112.0	97.2	860 lbs.

WHEN ORDERING SPECIFY VOLTAGE AND PHASE

Specifications subject to change without notice.

LANG MANUFACTURING COMPANY

6500 Merrill Creek Parkway, Everett, WA 98203 U.S.A.

PRINTED IN U.S.A.

61200-92 6/97

TOLL FREE 800/882-6368

PHONE 425/349-2400

FAX 425/349-2733