



Item No. _____
 Project _____
 Quantity _____

Electric, Full-Size/Standard Depth Convection Oven Model: ECCO-[AP/SII/PP/PT]



Model ECCO-PT shown, with optional 27" stand.

PAN CAPACITY GUIDE

Pan Type	Rack Positions	Optimum
18" X 26" Full-Sheet	10 or 11*	5
12" X 20" Hotel**	-	10

* AP & SII = 10; PP & PT = 11

** 2-1/2" deep pans

SHORT/BID SPECIFICATION

Convection Oven shall be a **LANG Manufacturing Model ECCO-** _____ with [AP=Accu-Plus, SII=Selectronic II, PP=Purple Plus or PT=Platinum] Control Package, an 11.66-kW electric heated 5-pan full-size unit, with: simultaneous-opening heavy duty doors; all stainless steel exterior and porcelainized steel cooking compartment; powerful rear mounted blower with two speed motor and pulse control; compartment inspection lights and five pan racks standard; plus a "lifetime" warranty on doors. Includes all the features listed and options/accessories checked:

STANDARD PRODUCT WARRANTY

- One year, parts & labor, plus
- Lifetime warranty on oven doors

CONSTRUCTION FEATURES

- Heavy duty 430 Series stainless steel exterior, with attractive No. 4 finish
- Fully enclosed oven back
- Cooking compartment is porcelainized steel
- 2" insulation on six sides of cooking compartment
- Heavy duty, simultaneously-opening compartment doors, with large double pane tempered glass windows
- Powerful blower centered in back of compartment
- Compartment inspection lighting standard
- Chrome steel 10 or 11 position pan slides with five chrome plated wire racks provided

PERFORMANCE FEATURES

- 150 to 450°F operating temperature range
- Solid state temperature control accurate to ± 4°F
- Two speed fan with fan pulse capability
- Door interlock switch cuts power to fan
- Choice of four different control packages [See below]

CONTROL PACKAGE [Specify One]

- Accu-Plus Controls [-AP]**
 - Simple knob-set time and temperature controls
 - 1-hour timer with non-stop buzzer
 - Pulse-fan switch
 - HIGH-LOW speed fan switch
 - Power-ON and inspection light switches
- Selectronic II Controls [-SII]**
 - Solid state temperature control with digital time/temperature display
 - Heat loss compensation
 - 10-hour countdown timer, with non-stop buzzer
 - Automatic Cook-n-Hold switch
 - Pulse-fan switch
 - HIGH-LOW speed fan switch
 - Power-ON and inspection light switches
- Purple Plus Controls [-PP]**
 - Solid state one-touch programmable controls
 - 10 product buttons, programmable up to four tiers
 - 4 X 20 character LCD display panel
 - Time, temperature, heat loss and adjustable shelf compensation
 - Cook-n-Hold programming
 - 2-speed fan & variable-rate pulse-fan control
 - Compartment inspection light switch
 - Power-ON switch
- Platinum Controls [-PT]**
 - Solid state, icon driven, one-touch programmable controls
 - Up to 99 product programs, with multiple baking tiers
 - Time, temperature, heat loss and adjustable shelf compensation
 - Cook-n-Hold programming
 - 2-speed fan & variable-rate pulse-fan control
 - PC link programming
 - Modem [Option]
 - Power-ON and inspection light touch pads



Sheet No. LSP-C5 (rev. 7/03)

Electric, Full-Size/Standard Depth Convection Oven **Model: ECCO-[AP/SI/PP/PT]**

INSTALLATION REQUIREMENTS

- (E) Site changeable dual voltage: 208V/240V, 1- or 3-Phase; or optional 480V, 3-phase electrical connection
- Installation under approved vent hood required [Power connection from rear. See below]

OPTIONS & ACCESSORIES

- 480V, 3-phase model [no charge]
- 27" stainless steel angular legs
- 27" stainless steel tubular leg stands with under shelf & bullet feet
- 27" stainless steel tubular leg stands with under shelf, pan slides & bullet feet
- 27" stainless steel tubular leg stands with under shelf & casters
- 27" stainless steel tubular leg stands with under shelf, pan slides & casters
- Factory installed modem [Platinum/-PT models only]
- Factory recipe programming [Purple Plus/-PP & Platinum/-PT models only]
- Steam injection option [Purple Plus/-PP & Platinum/-PT models only]
- 3" stainless steel spacer
- Solid stainless steel doors, in lieu of doors with windows
- Extra wire pan racks [5 provided as std.]

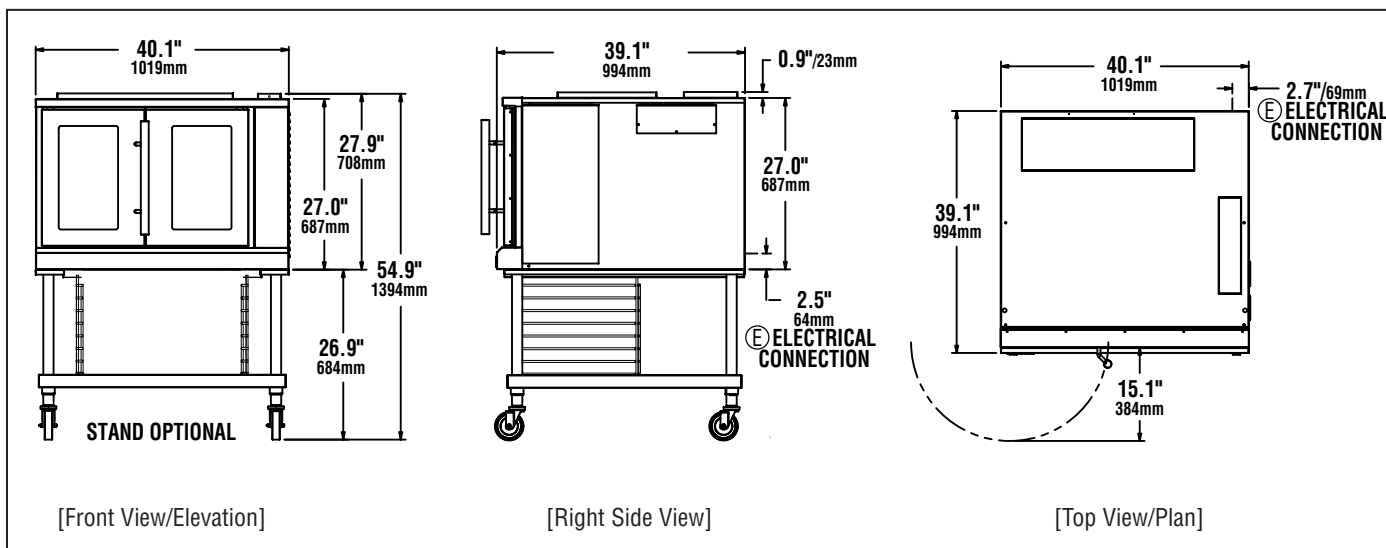

Model	Height x Width x Depth (without optional stand)	Clearance from combustible surface	Weight		Freight Class
			Actual	Shipping	
ECCO	27.9" x 40.2" x 38.8" 708mm x 1019mm x 985mm	Sides: 6" (153mm) Back: 6" (153mm) Floor: 6" (153mm)	380 lbs. 173 kg	420 lbs. 191 kg	70

Model	(E) Electrical Requirements			
	Voltage	Total kW	Phase	Amps/Line
ECCO	208V/60Hz	11.7	1	56.1
	240V/60Hz	11.7	1	48.6
	480V/60Hz	11.7	1	24.3
	208V/60Hz	11.7	3	37.1
	240V/60Hz	11.7	3	28.8
	480V/60Hz	11.7	3	16.1

CAD SYMBOLS & PRICING



Due to continuous improvements, specifications subject to change without notice.



Sheet No. LSP-C5 (rev. 7/03)

LANG MANUFACTURING COMPANY • 6500 Merrill Creek Parkway, Everett, WA 98203
TOLL FREE: 800.882.6368 • FAX: 425.349.2733 • www.langworld.com