



Thermostatically Controlled

- The thermostatically controlled Accu-Temp Gas Convection Oven accurately senses temperature, giving an even and consistent bake.
- Two-Speed and Pulse Fan features are standard. With the Pulse Fan feature, the fan only comes on when the oven calls for heat, keeping delicate food products safe.
- Energy-Saving features include electronic spark ignition, funnel-flow heat recirculation system, insulation on all sides and double-pane, tempered glass windows in the doors.
- The GCCO-T Oven is rated for 55,000 BTU's.
- The oven includes an automatic interlock switch, which turns the fan motor and heat off when the doors are opened.
- Standard exterior finish is stainless steel.
- Oven interior is porcelainized steel, with inspection-only lighting.
- Each oven provided with a safety shut-off valve.
- The oven is U.L. Listed and N.S.F. certified.
- Standard warranty shall cover parts and labor for one full year.

Lifetime warranty on full-size oven doors!

LANG MANUFACTURING COMPANY
 6500 Merrill Creek Parkway
 Everett, WA 98203
 TOLL FREE (800) 882-6368
 PHONE (425) 349-2400
 SERVICE (800) 224-5264
 FAX (425) 349-2733

ITEM NO.
MODEL NO.
©1200 91 6997 Printed in U.S.A.

“ACCU-TEMP” Full-Size GAS CONVECTION OVEN

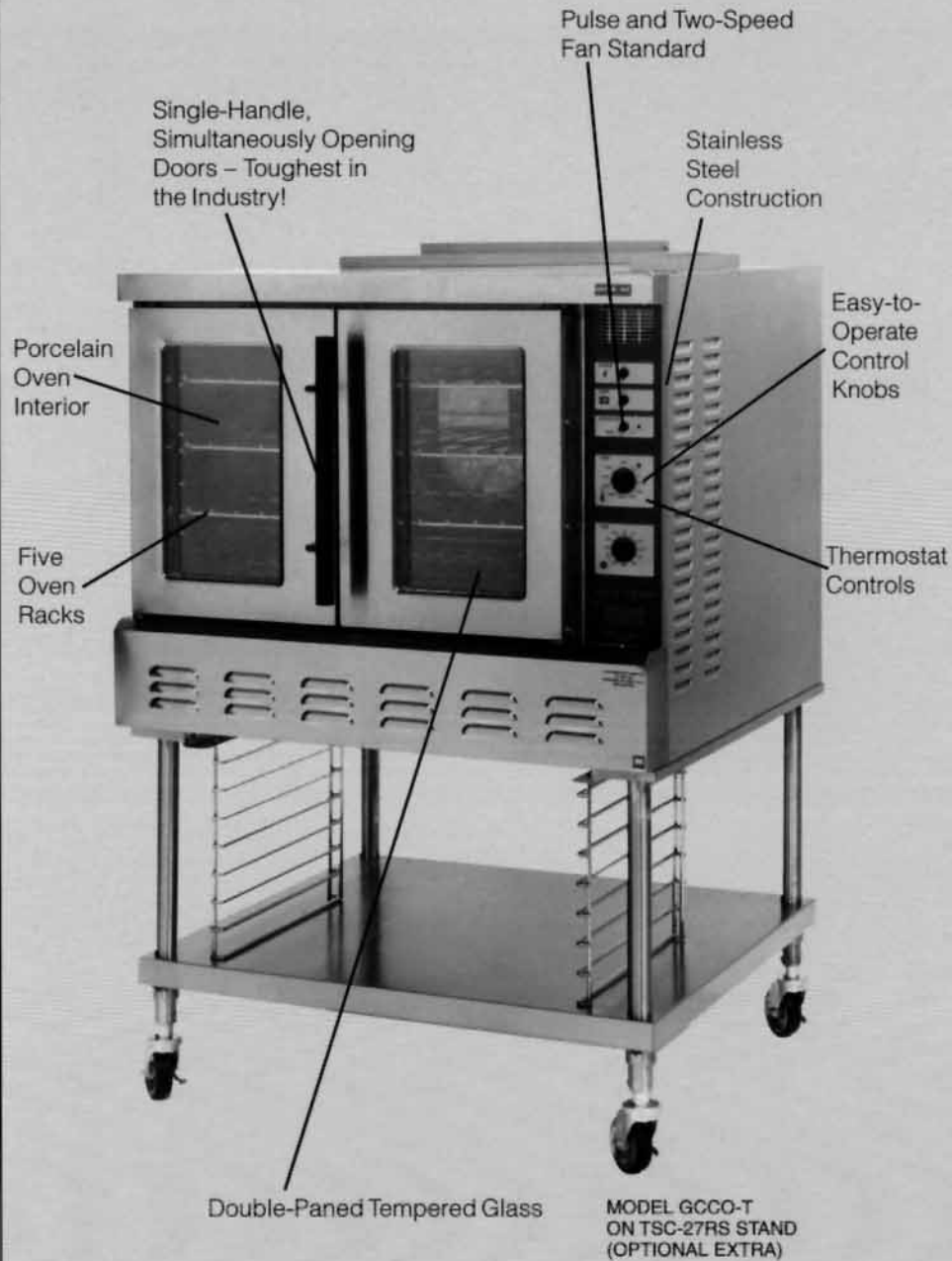

ALSO AVAILABLE IN STANDARD DEPTH ELECTRIC AND GAS EXTRA DEEP SIZES.

Specifications subject to change without notice.





SPECIFICATIONS FOR GAS "ACCU-TEMP" CONVECTION OVEN

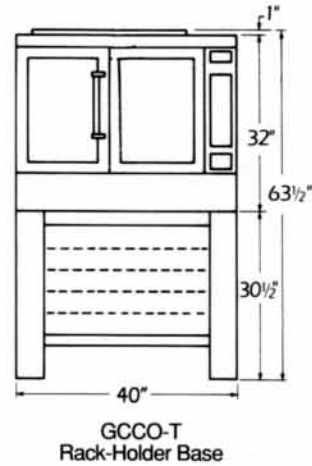
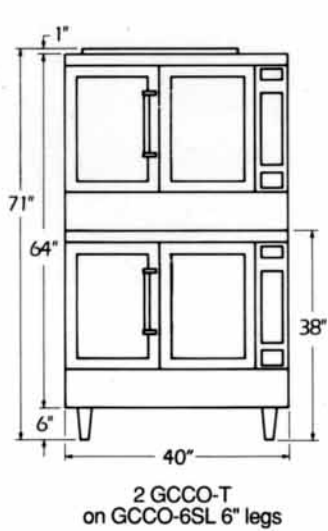
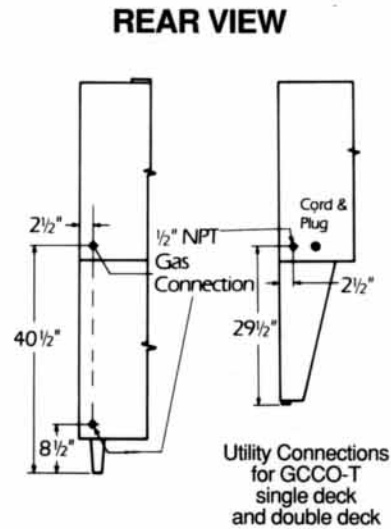
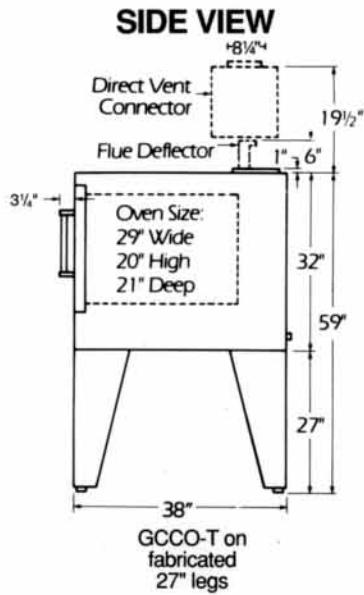

SPACING REQUIREMENTS: 4" from sides & back; 6" from floor. Recommended spacing for venting: 12" minimum clearance on RIGHT side when banked with other cooking equipment. 3" wide stainless steel spacers available as accessories to reduce recommended venting clearances. See price list.

Model Number	BTU's per Oven		Gas Connection	Electrical Conn. Single Phase	Cord/Plug & Pressure Regulator	Shipping Weight
	Natural	Propane				
GCCO-T	55,000	55,000	One - 1/2" NPT	One 120VAC, 7.1 AMPS	One Supplied	500 lbs.
2GCCO-T	110,000	110,000	Two - 1/2" NPT	Two 120VAC, 7.1 AMPS	Two Supplied	1000 lbs.

Gas input ratings shown are for installations up to 2000 feet above sea level. BTU ratings must be derated for altitudes above 2000 feet. Specify altitude of project if over 2000 feet. Ovens may be installed on combustible surface with 6 inch legs or without legs on non-combustible surface. When ordering specify natural or propane gas.

Water Column: 5" for Natural Gas; 10" for L.P. Gas

Ordering Requirements:

For direct venting, a "DIRECT VENT CONNECTOR" must be installed — see price list.

WHEN ORDERING SPECIFY VOLTAGE AND PHASE

Specifications subject to change without notice.

LANG MANUFACTURING COMPANY

6500 Merrill Creek Parkway, Everett, WA 98203 U.S.A.

PRINTED IN U.S.A.

61200-01 6/97

TOLL FREE 800/882-6368
PHONE 425/349-2400
FAX 425/349-2733