

# MONTAGUE LEGEND



## Hearth Bake

### Gas Pizza Ovens - Double Deck 23P-2, 24P-2 and 25P-2

#### GENERAL

**23P-2** -- Double Oven, 62" wide x 40-1/2" deep overall.  
(157.5 wide x 102.9 deep cm) overall.  
Interior: 8" high x 41-1/2" wide x 31" deep.  
(20.3 high x 105.4 wide x 78.7 deep cm).

**24P-2** -- Double Oven, 69" wide x 45-1/2" deep overall.  
(175.3 wide x 115.6 deep cm) overall.  
Interior: 8" high x 48-1/2" wide x 36" deep.  
(20.3 high x 123.2 wide x 91.4 deep cm)

**25P-2** -- Double Oven, 81" wide x 45-1/2" deep overall.  
(205.7 wide x 115.6 deep cm) overall.  
Interior: 8" high x 60-1/2" wide x 36" deep.  
(20.3 high x 153.7 wide x 91.4 deep cm)

Two separately controlled ovens, (stacked). Total overall height 73-3/8" (186.4 cm) including the legs and the flue riser. Durable exterior construction - 18 gauge steel panels welded to a 1-1/4" x 1-1/4" x 1/8" (3.2 x 3.2 x .3 cm) steel angle frame. Plus energy efficient and easy maintenance.

Production Power with versatility. Designed for constant high volume pizza production but not limited to pizzas! Try baking casseroles, breads and other products on the optional fire brick hearths or steel deck. Maximum food height: 7" (17.8 cm).

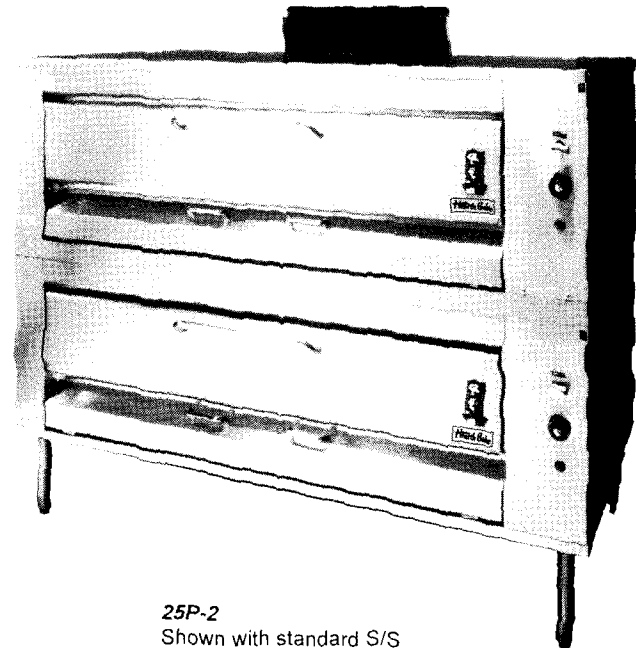

**25P-2**  
Shown with standard S/S front and 12" (30.5 cm) legs.

#### STANDARD FEATURES

##### OVEN INTERIOR:

- 1-1/2" (3.8 cm) Cordierite three-piece deck for **hearth baking**. SIDES, BACK AND TOP LINED WITH FIRE BRICK for heat retention and quick recovery time.

##### OVEN DOOR:

- Drop-down type with aluminized steel interior door liner. Full width for easy access to entire hearth. Weight counter balanced for a tight seal and smooth solid closing action. No springs to replace. Handle is one piece offset tubular-type; nickel plated, cold roll.

##### FIRE DOOR WITH CRUMB EJECTOR:

- Provides easy access to combustion chamber for manual ignition of constant burning pilot; burner adjustment and easier cleaning.

##### INSULATION:

- Heat stable high temperature Fiberglas. Provides a thermal blanket designed for high insulating efficiency; conserving energy and providing a cooler atmosphere. Sides and Back, double layer, 2" (5.1 cm) thick battens. Top, triple layer, 2" (5.1 cm) thick battens. Door, double layer, 1-1/2" (3.8 cm) battens.

##### CONTROLS:

- 300°F (148°C) to 650°F (343°C) throttling type thermostat provides quick heat recovery; shuts off instantly at desired temperature; saves energy. 100% safety pilot for automatic ignition. Safety pilot shuts off gas flow if pilot light is extinguished.

##### BURNERS AND AIR MIXERS:

- Removable long life cast iron burners rated at 40,000 BTU/HR each. Air mixers have adjustable air shutters with locking device.

#### STANDARD FEATURES, (cont.)

##### LEGS:

- 12" (30.5 cm) high tubular legs with adjustable feet for leveling.

##### FINISH

##### EXTERIOR:

Standard - Satin stainless steel front. Remaining exterior black. All painted surfaces have electrolytic zinc undercoating for corrosion protection and longer life.

Optional: (\*extra cost):

- \*S/S left side     \*S/S right side     \*S/S top
- \*S/S back

Note: All black finish with stainless trim available.

#### OPTIONS, (\*extra cost)

##### OVEN INTERIOR

- \*Fire Brick Hearths
- Steel Deck (for pan baking)

##### DOWN DRAFT DIVERTER, (in-lieu-of std. flue deflector).

Note: Used for direct flue connection, (in-lieu-of ventilation hood), if local codes permit. Check codes for ventilation requirements.     \*S/S     \*Black

##### CUSTOM EXTERIOR DECORS:

- Consult factory



# MONTAGUE LEGEND

## Heavy Duty Pizza Ovens - Double Deck

Dimensions in parenthesis are centimeters.

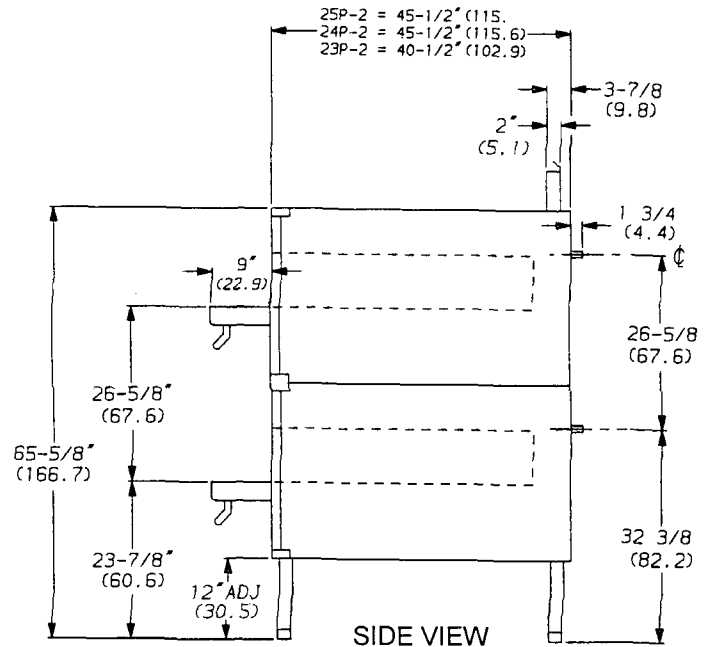
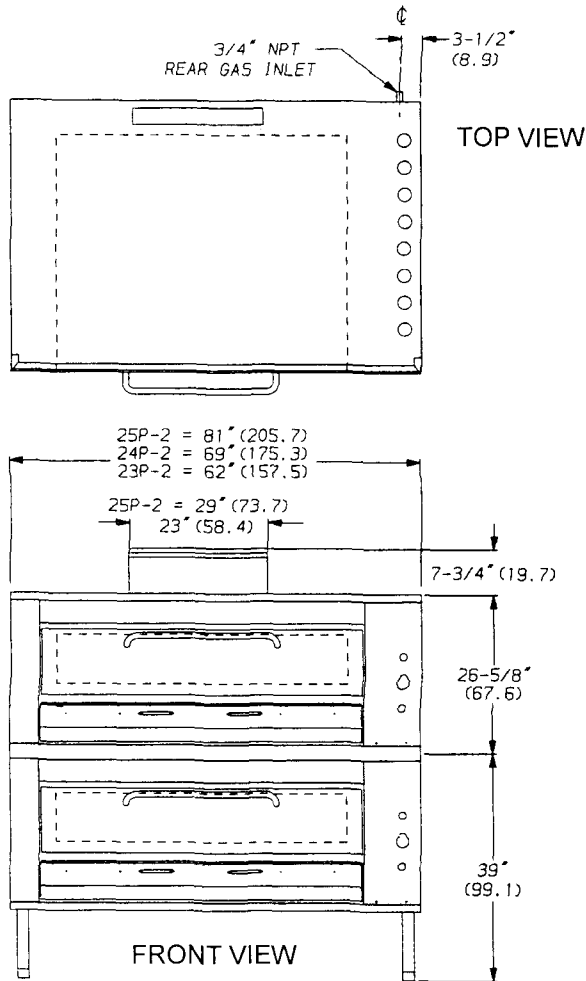

### IMPORTANT:

Commercial Oven(s) must be installed in accordance with local codes, with the National Fuel Gas Code, ANSI Z223.1, Natural Gas Installation Code, CAN/CGA-B149.1, or the Propane Installation Code, CAN/CGA-B149.2, as applicable. Compliance with codes is the responsibility of the Owner and Installer.

Adequate Ventilation System required. Refer to NFPA 96, Standard for Ventilation Control and Fire Protection of Commercial Cooking Operations.

Type Gas:		Natural	Propane	Interior dimensions per deck			Pizza capacity per deck	
Model	# Burners	Total Btu/Hr	Total Btu/Hr	H	D	W	12" or 18"	
23P-2	4	160,000	160,000	8" x 31" x 41-1/2"	6 ea.	2 ea.		
24P-2	6	240,000	240,000	8" x 36" x 48-1/2"	8 ea.	4 ea.		
25P-2	8	320,000	320,000	8" x 36" x 60-1/2"	10 ea.	6 ea.		

### GAS INLET SIZE (for all models):

One 3/4" (1.9 cm) NPT at right rear. Two 3/4" (1.9 cm) NPT gas pressure regulator is provided. Regulators must be installed when appliance is connected to gas supply.

Optional, \*(extra cost):

\*Manifold assembly for single 3/4" (1.9 cm) NPT gas inlet.

NOTE: Specify type of gas  Natural  Propane  
Specify elevation if installing above 2000 feet.

### ENTRY CLEARANCE: (23P-2, 24P-2, 25P-2)

All.....27" (68.6 cm) uncrated

### APPROX. CU. FT./CU. METER:

23P-2 Oven (2) carton: 51/1.44  
Top Fire Brick (2) carton: 5/0.14  
**Total:** 112/3.17

### SHIPPING WEIGHTS:

826 lbs./375 kg.  
130 lbs./59 kg.  
1912 lbs./867 kg.

24P-2 Oven (2) carton: 64/1.81  
Top Fire Brick (2) carton: 5/0.14  
**Total:** 138/3.91

1130 lbs./513 kg.  
150 lbs./68 kg.  
2560 lbs./1161 kg.

25P-2 Oven (2) carton: 82/2.32  
Top Fire Brick (2) carton: 5/0.14  
**Total:** 174/4.93

1560 lbs./708 kg.  
190 lbs./86 kg.  
3500 lbs./1588 kg.

Montague's continuing commitment to quality/product improvement can cause specification and design changes without prior notice.

Minimum Clearances:	Combustible Construction	Noncombustible Construction
Back Wall:	3"	3"
Left & Right Side:	1"	0"

With 12" legs: Suit for installation on combustible floors.

**AGA and CGA Design Certified:** In accordance with ANSI Z83.11 • CGA 1.8 Food Service Equipment - Ranges.  
Note: These appliances are intended for commercial use by professionally trained personnel. *NOT Intended For Household Use*

**Pizzaovens.com**  
Your Complete Source  
for buying the right equipment