



# VECTAIRE™ Full-Size Bakery Depth Electric Convection Oven

Item No. \_\_\_\_\_

Project \_\_\_\_\_

Quantity \_\_\_\_\_

## SLEK15 Series



Model SLEK15AP Shown  
with optional casters

### SHORT/BID SPECIFICATION

Convection oven shall be a Montague *Vectaire* full-size electric Model:

- SLEK15** a single bakery depth 15-kW unit with 24" (610mm) black painted, gusset-style legs

[Specify controls]:

- AH, Cook-n-Hold Controls** with: solid state 150-500°F (66-260°C) thermostat with RTD platinum temperature sensor, 24-hour digital countdown timer with alarm, programmable HOLD feature and burner-ON indicator
- AP, Programmable Controls** with: five-button menu pad, plus all Cook-n-Hold Controls including: solid state 150-500°F (66-260°C) thermostat with RTD platinum temperature sensor, 24-hour digital countdown timer with alarm, programmable HOLD feature and burner-ON indicator

...with three tubular heating elements in one group of three; a porcelainized steel oven interior with one-speed [bakery] fan; nine rack positions, five bright nickel racks with rack stops and no-tip guides standard; two 50-50 stainless steel doors with double pane viewing windows; plus all the features listed and options/accessories checked

### MODEL-PAN/RACK GUIDE:

✓	Model No.	Oven Depth	Racks/Positions	Rack Spacing	
				5-racks	9-racks
	SLEK15	Bakery*	5/9	3-3/8" (86mm)	1-1/2" (38mm)

\*18" x 26" (457 x 660mm) sheet pans length or sideways

### OVEN INTERIOR CONSTRUCTION:

- Porcelainized steel cooking compartment
- Nine-position bright nickel rack guides
- Five bright nickel pan racks, with rack-stop and no-tip guides standard
- Two covered interior lights
- 4" (102mm) of insulation compressed to 2" (51mm) with metal sheathing

### HEATING ELEMENTS & BLOWER SYSTEM:

- Six 2.5-kW heating elements grouped in two sets
- Blower with 3/4-horsepower single-speed motor

### EXTERIOR CONSTRUCTION FEATURES:

- Satin finish stainless steel front, sides and top
- Black painted steel back and legs
- Ball bearing mounted 50-50 double door
- Double pane thermal viewing windows
- Tubular grab-bar handle with insulated comfort grip
- Durable, adjustable door gasket
- 24" (610mm) legs gusset-style legs with adjustable bullet feet

### CONTROL FEATURES:

- Power-ON switch
- Oven-ON indicator light
- Moisture Vent
- Cook-n-Hold -AH Package:**
  - Solid state 150-500°F (66-260°C) thermostat
  - Programmable 140-200°F (63-93°C) HOLD feature
  - Precise RTD platinum temperature probe
  - 24-hour digital countdown timer with alarm
  - Up to 20 min. pulsed fan intervals (IFO)
- Programmable -AP Package:**
  - Five button programmable menu pad, plus:
  - Solid state 150-500°F (66-260°C) thermostat
  - Programmable 140-200°F (63-93°C) HOLD feature
  - Precise RTD platinum temperature probe
  - 24-hour digital countdown timer with alarm
  - Up to 20 min. pulsed fan intervals (IFO)

### AGENCY APPROVALS

- NSF Listed
- UL Listed (ANSI/UL-197)



VC0-12 [Rev. 1/13]

# VECTAIRE™ Full-Size Standard Bakery Depth Electric Convection Oven

Item No. \_\_\_\_\_

Project \_\_\_\_\_

Quantity \_\_\_\_\_

## SLEK15 Series

Dimensions in brackets are millimeters

⊙ DENOTES 1" DIA. KNOCKOUT FOR FIELD SUPPLY CONNECTION

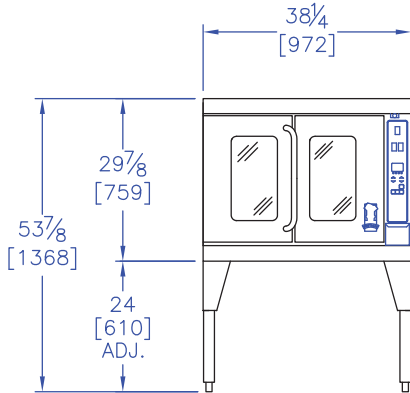

**FRONT VIEW**

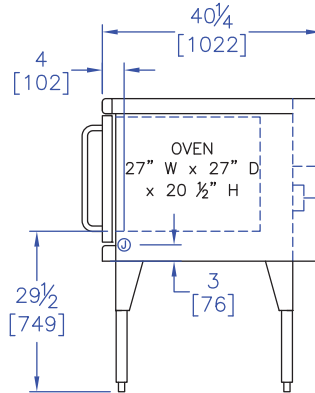

**RIGHT SIDE VIEW**

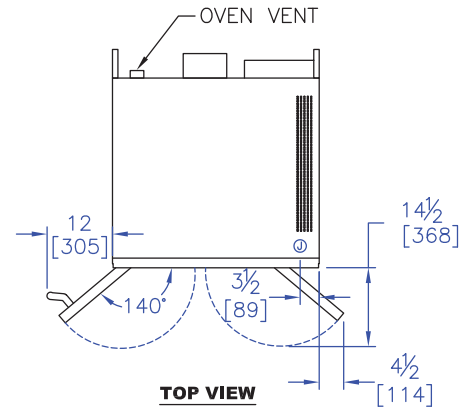

**TOP VIEW**

### OPTIONS GUIDE:

#### Installation Alternatives:

- Stacking Kit (for bottom unit)
- Stem casters 5" (127mm) for use with Gusset-style legs
- Modular Stand [open base] with 4" (102 mm) frame, stainless steel front, lower shelf and 19-1/2" (495mm) stainless steel legs
  - 3-1/2" (89mm) stem casters
  - 9-position removable pan slides (for stand)
- Heat Shield Kit-[See minimum clearances]

#### Electric, Controls & Motor Alternatives:

- Two speed fan motor [for SLEK15, 1-pH only]

#### Finish:

- Full stainless steel oven interior [-ASC suffix]
- Stainless steel louvered back panel
- 24" (610mm) Stainless steel gusset-style legs
- Stainless steel exterior bottom

#### Racks & Security:

- Stainless steel drip tray
- Extra Racks: \_\_\_\_ ea. std.; \_\_\_\_ ea. heavy duty
- 11-position rack guides [set of two]
- Solid Doors [in place of windows]
- Security Options [Consult Factory]

### INSTALLATION REQUIREMENTS & SHIPPING INFORMATION

- Oven must be installed in accordance with local codes or in their absence with the National Electric Code: ANSI/NFPA 70. Compliance with codes is the responsibility of the Owner and Installer.
- An adequate ventilation system is required. Refer to National Fire Protection Association Standard No. 96, "Vapor Removal from Cooking Equipment."
- This appliance is intended for commercial use by professionally trained personnel. NOT intended for Residential Use.

Minimum Clearances	Combustible Construction	Noncombustible Construction
From Back Wall	0"	0"
Left & Right Side*	0"	0"
<b>Unit must be mounted on legs, cabinet or stand.</b>		

#### Electric Requirements\*

Voltage	Phase	Hz	Total kW	Nominal AMP/Line SLEK15			Minimum Circuit Capacity SLEK15
			SLEK15	L1	L2	L3	
208	1	60	15.15	78			98
240	1	60	15.15	69			98
208	3	60	15.15	43	43	41	54
240	3	60	15.15	40	40	36	54
480	3	60	15.15	22	22	19	27

\*Other Voltage/Hz models available. Contact factory.

#### Shipping Information:

Models	Weight	Shipping Class	Cube (Crated) ft <sup>3</sup> /m <sup>3</sup>
<b>SLEK15 [all]</b>	452 lbs (205 kg)	70	37/1
<b>Modular Stand w/shelf</b>	add 78 lbs (35 kg)	70	21/.6
Entry clearance 30" (762mm) uncrated			

Due to continuous product improvements, specifications are subject to change without notice.



## THE MONTAGUE COMPANY

1830 Stearman Avenue, Hayward, CA 94545  
 800 345-1830 • Fax: 510 785-3342  
 www.montaguecompany.com

