



*Model SDG-1  
 (shown with optional stainless  
 steel exterior package)*

**Specification:**

Full-size, deep depth, gas convection oven with electro-mechanical thermostat, 60-minute timer and 2-speed fan. Designed as a general purpose oven for baking or roasting a variety of food products faster and at lower temperatures by circulating air throughout the oven cavity.

**Standard Features:**

- Electromechanical thermostat with a temperature range of 200°F - 500°F (93°C - 260°C), and 60-minute timer
- Electronic spark ignition, including automatic pilot system with 100% safety shut off
- Total of 80,000 BTU loading per oven cavity
- Natural or Propane
- Two-speed fan with 3/4 HP motor
- 60/40 dependent door design with double pane thermal window in both doors
- Interior lights
- Porcelain enameled oven interior w/coved corners
- Five (5) chrome plated oven racks on 11-position, removable rack guides
- Stainless steel front, black powder coat epoxy sides, top, and legs
- Double-deck model available, (SDG-2)

**Optional Features:**

- Stainless steel exterior package, (includes top, sides and legs)
- Extra oven racks
- Swivel casters, set of four; two locking, (please specify single or double deck)
- Canopy diverter, (specify stainless steel or black powder-coat epoxy)
- Direct connect vent, (specify single or double oven)

NOTE: Ovens supplied with casters must be installed with an approved restraining device)





Item #: \_\_\_\_\_  
 Models: SDG-1, SDG-2  
 Product Name: SunFire Gas  
 Convection Oven

Width	Depth	Height		Oven Interior Dimensions			Combustible Wall Clearance	
		SDG-1	SDG-2	Height	Depth	Width	Sides	Rear
40" (1016mm)	44-1/2" (1130mm)	60" (1524mm)	72" (1829mm)	20-1/2" (520mm)	28-1/2" (723mm)	29" (736mm)	1" (25mm)	6" (152mm)

Model	Total BTU Load	Operating Manifold Pressure			Electrical Characteristics	Shipping Information		
		NAT	PRO	MAX		Lbs.	Kg	Cube
SDG-1	80,000	4" WC	9.5" WC	13.8" WC @ 70°F	120VAC, 1Ø, 9.4 Amps	700	315	58.0
SDG-2	160,000				2@120VAC, 1Ø, 9.4 Amps	1400	630	114.0

Model	Entry Clearances	
	Crated	Uncrated
SDG-1	47"	32-1/2"
SDG-2	(1194mm)	(826mm)

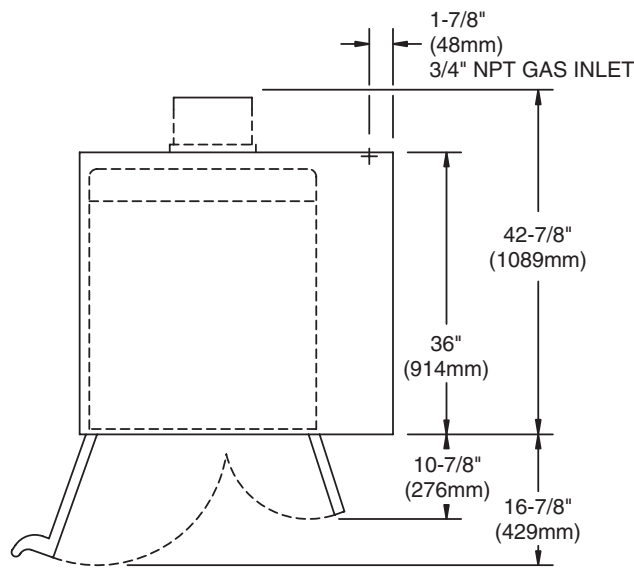

- These appliances are intended for commercial use by professionally trained personnel.
- It is the responsibility of the installer to ensure that installation complies with all national and local codes.

