

MODEL VEC3624 ELECTRIC CONVEYOR OVEN



Listed to UL 197 by ITS
Classified to ANSI/NSF Standard 4 by ITS
Certified for Canada



SPECIFICATIONS:

72½" long electric conveyor pizza oven, Vulcan-Hart Model No. VEC3624. Stainless steel front, sides and top. 36" x 24" d baking chamber. 4¾" product clearance. Stainless steel front access door permits front loading for shorter bake times. Stainless steel conveyor belt measures 72" l x 24" w. Reversible belt drive with variable speed controls. Six 5 KW open type heating elements, 30 KW total input. Electronic temperature controls with digital read-outs. High velocity precision targeted air flow for consistent, repeatable baking results. Removable stainless steel crumb trays and front access panel for ease of cleaning. 208 or 240 volt, 60 Hz, 1 or 3 phase power supply.

Exterior dimensions:

72½" l x 42" d x 48" h on 23" stainless steel legs.

72½" l x 42" d x 42" h on 17" stainless steel legs.

SPECIFY BELT ROTATION (L-R) (R-L).

SPECIFY LEGS.

STANDARD FEATURES

- Stainless steel front, sides and top.
- 36" x 24" d baking chamber. 4¾" product clearance.
- Stainless steel conveyor belt measures 72" l x 24" w.
- Reversible belt drive with variable speed controls.
- Six 5 KW open type heating elements, 30 KW total input.
- Electronic temperature controls with digital read-outs.
- High velocity precision targeted air flow for consistent, repeatable baking results.
- Removable stainless steel crumb trays and front access panel for ease of cleaning.
- Stainless steel front access door permits front loading for short bake times.
- 208 or 240 volt, 60 Hz, 1 or 3 phase power supply
- One year limited parts and labor warranty.

OPTIONS & ACCESSORIES

- 23" stainless steel legs with casters, two locking.
- 17" stainless steel legs with casters, two locking, for double stack oven.
- 12" stainless steel apron extension (specify left or right).
- 18" stainless steel apron extension (specify left or right).
- Second year extended limited parts and labor warranty.



Restaurant Equipment Worldwide
Toll Free: 877.FOR.OVEN

International: +1 859.885.1988

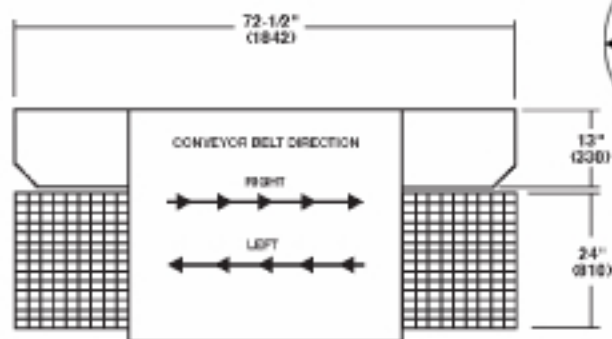
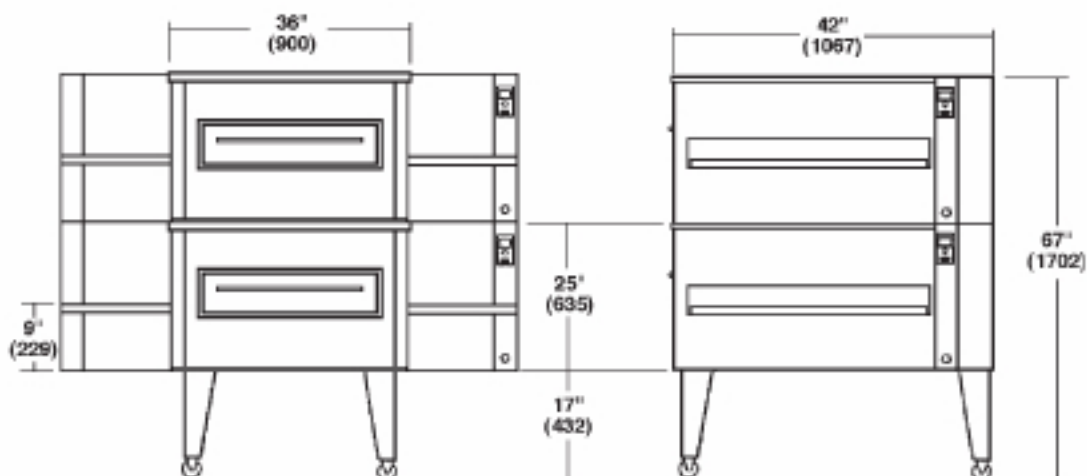
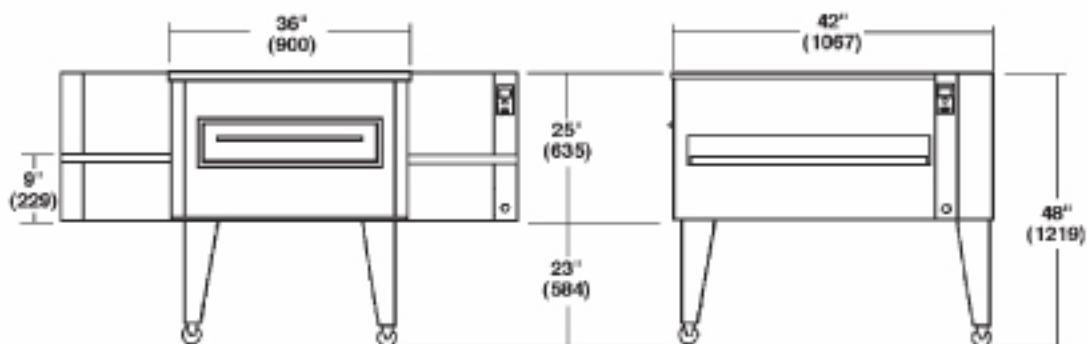

Restaurant Equipment Worldwide
Toll Free: 877.FOR.OVEN
International: +1859.885.1988

MODEL	EXTERIOR DIMENSIONS*	BELT DIMENSIONS	ELECTRICAL						APPROX. SHIP. WT.
			208V			240V			
			Ph	Amps	Hz	Ph	Amps	Hz	
VEC3624	72½"l x 42"d x 48"h	24"w x 72"l	1	144	60	1	125	60	850 lbs. 184 kg
			3	83	60	3	72	60	

* Single oven on 23" legs.

NOTE: In line with its policy to continually improve its products, Vulcan-Hart Company reserves the right to change materials and specifications without notice.