

VULCAN

Item # _____

C.S.I. Section 11420

MODEL VEC4832 ELECTRIC CONVEYOR OVEN



Listed to UL 197 by ITS
Classified to ANSI/NSF Standard 4 by ITS
Certified for Canada



SPECIFICATIONS:

84½" long electric conveyor pizza oven, Vulcan-Hart Model No. VEC4832. Stainless steel front, sides and top. 48" x 32"d baking chamber. 4¾" product clearance. Stainless steel front access door permits front loading for shorter bake times. Stainless steel conveyor belt measures 84" x 32"w. Reversible belt drive with variable speed controls. Nine 5 KW open type heating elements, 45 KW total input. Electronic temperature controls with digital read-outs. High velocity precision targeted air flow for consistent, repeatable baking results. Removable stainless steel crumb trays and front access panel for ease of cleaning. 23" stainless steel legs with casters, two locking. 208 or 240 volt, 60 Hz, 1 or 3 phase power supply.

Exterior dimensions:

84½" l x 50" d x 48" h on 23" stainless steel legs.
84½" l x 50" d x 42" h on 17" stainless steel legs.

SPECIFY BELT ROTATION (L-R) (R-L).

SPECIFY LEGS.

STANDARD FEATURES

- Stainless steel front, sides and top.
- 48" l x 32" d baking chamber. 4¾" product clearance.
- Stainless steel conveyor belt measures 84" l x 32" w.
- Reversible belt drive with variable speed controls.
- Nine 5 KW open type heating elements, 45 KW total input.
- Electronic temperature controls with digital read-outs.
- High velocity precision targeted air flow for consistent, repeatable baking results.
- Removable stainless steel crumb trays and front access panel for ease of cleaning.
- Stainless steel front access door permits front loading for short bake times.
- 208 or 240 volt, 60 Hz, 1 or 3 phase power supply.
- One year limited parts and labor warranty.

OPTIONS & ACCESSORIES

- Split conveyor belt.
- 23" stainless steel legs with casters, two locking.
- 17" stainless steel legs with casters, two locking, for double stack oven.
- 12" stainless steel apron extension (specify left or right).
- 18" stainless steel apron extension (specify left or right).
- Second year extended limited parts and labor warranty.



VULCAN



ANSI/NSF
Standard
4 Certified
Vulcan-Hart Co.

MODEL: VEC4832 Electric Conveyor Oven



MODEL VEC4832

ELECTRIC CONVEYOR OVEN

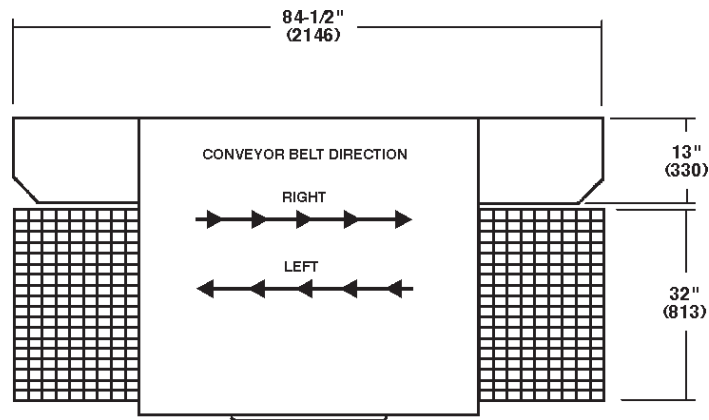
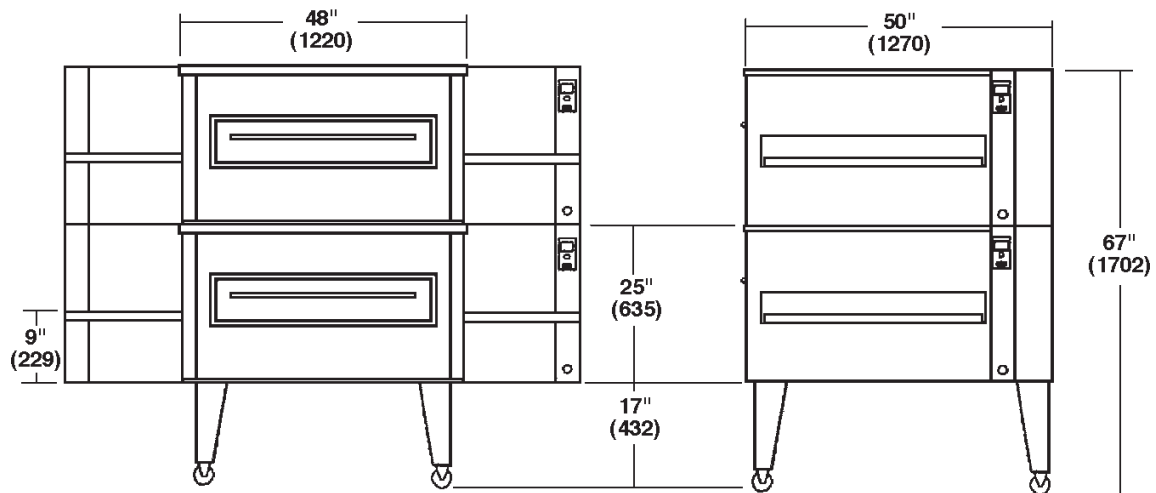
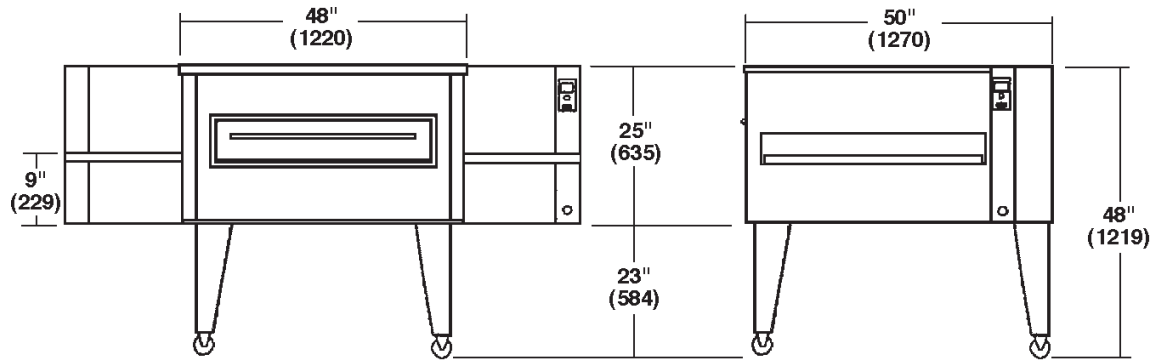

MODEL	EXTERIOR DIMENSIONS*	BELT DIMENSIONS	ELECTRICAL						APPROX. SHIP. WT.
			208V			240V			
			Ph	Amps	Hz	Ph	Amps	Hz	
VEC4832	84½"l x 50"d x 48"h	32"w x 84"l	1	216	60	1	188	60	1050 lbs. 227 kg
			3	125	60	3	108	60	

* Single oven on 23" legs.

NOTE: In line with its policy to continually improve its products, Vulcan-Hart Company reserves the right to change materials and specifications without notice.