

## MODEL VGC6024 GAS CONVEYOR OVEN



Classified to ANSI Z83.11 • CGA 1.8 by ITS  
Classified to ANSI/NSF Standard 4 by ITS  
Certified for Canada



### SPECIFICATIONS:

96½" long gas conveyor pizza oven, Vulcan-Hart Model No. VGC6024. Stainless steel front, sides and top. 60"l x 24"d baking chamber. 4¾" product clearance. Stainless steel front access door permits front loading for shorter bake times. Stainless steel conveyor belt measures 96"l x 24"w. Reversible belt drive with variable speed controls. 140,000 BTU/hr. high efficiency gas power burner. Electronic temperature controls with digital read-outs. High velocity precision targeted air flow for consistent, repeatable baking results. Removable stainless steel crumb trays and front access panel for ease of cleaning. ¾" rear gas connection with combination gas control valve. 6' cord and plug, 120/60/1, 13.5 amps.

### Exterior dimensions:

96½"l x 42"d x 48"h on 23" stainless steel legs.

96½"l x 42"d x 42"h on 17" stainless steel legs.

**SPECIFY TYPE OF GAS WHEN ORDERING.**

**SPECIFY BELT ROTATION (L-R) (R-L).**

**SPECIFY LEGS.**

### STANDARD FEATURES

- Stainless steel front, sides and top.
- 60"l x 24"d baking chamber. 4¾" product clearance.
- Stainless steel conveyor belt measures 96"l x 24"w.
- Reversible belt drive with variable speed controls.
- 140,000 BTU/hr. high efficiency gas power burner.
- Electronic temperature controls with digital read-outs.
- High velocity precision targeted air flow for consistent, repeatable baking results.
- Removable stainless steel crumb trays and front access panel for ease of cleaning.
- Stainless steel front access door permits front loading for short bake times.
- ¾" rear gas connection and combination gas control valve.
- 6' cord and plug, 120/60/1, 13.5 amps.
- One year limited parts and labor warranty.

### OPTIONS & ACCESSORIES

- 23" stainless steel legs with casters, two locking.
- 17" stainless steel legs with casters, two locking, for double stack oven.
- 12" stainless steel apron extension (specify left or right).
- 18" stainless steel apron extension (specify left or right).
- 4' flexible gas hose with quick disconnect and restraining device.
- Second year extended limited parts and labor warranty.



**Restaurant Equipment Worldwide**  
**Toll Free: 877.FOR.OVEN**  
**International: +1 859.885.1988**

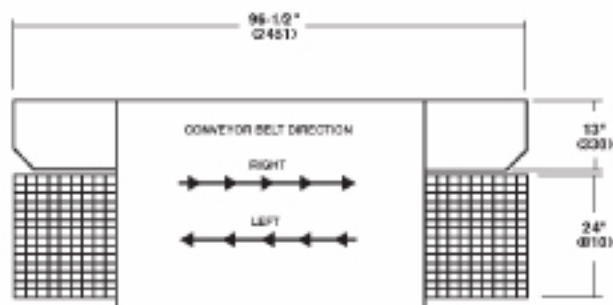

**Restaurant Equipment Worldwide**  
Toll Free: 877.FOR.OVEN  
International: +1 859.885.1988

### IMPORTANT

1. A combination gas control valve sized for this unit is included.  
Natural gas 7" W.C., propane gas 11" W.C.
2. Gas line connecting to range must be 3/4" or larger for a single oven, 1" or larger for a double stack oven and 1 1/4" or larger for a triple stack oven. If flexible connectors are used, the inside diameter must be at least the same as the iron pipe and rated for the correct gas input.
3. An adequate ventilation system is required for commercial cooking equipment. Information may be obtained by writing to the National Fire Protection Association, Batterymarch Park, Quincy, MA 02289. When writing, refer to NFPA No. 96.
4. These units are manufactured for installation in accordance with ANSZ223.1A (latest edition), National Fuel Gas Code. Copies may be obtained from the American Gas Association, 1515 Wilson Blvd., Arlington, VA 22209.
5. Clearances:
 

|       | Combustible | Non-comb. |
|-------|-------------|-----------|
| Rear  | 2 1/2"      | 2 1/2"    |
| Sides | 2 1/2"      | 2 1/2"    |
6. This appliance is manufactured for commercial installation only and is not intended for home use.

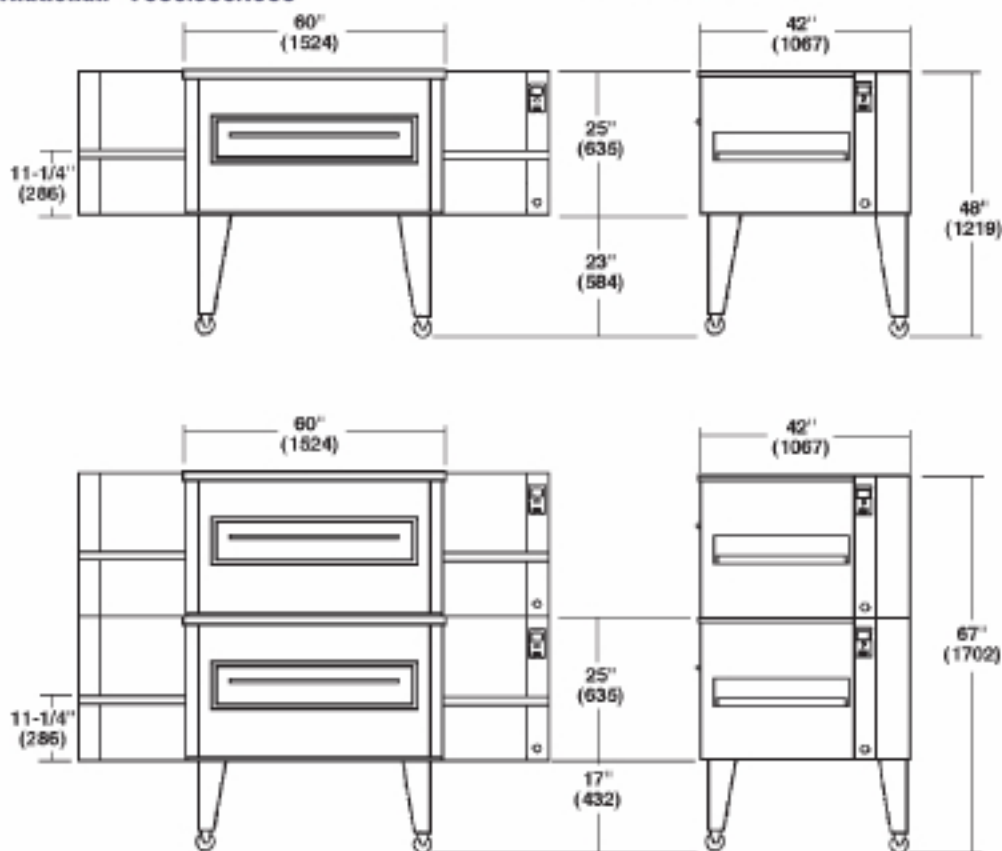

| MODEL   | EXTERIOR DIMENSIONS*      | BELT DIMENSIONS | ELECTRIC         | B.T.U.  | APPROX. SHIP. WT. |
|---------|---------------------------|-----------------|------------------|---------|-------------------|
| VGC6024 | 96 1/2" l x 42" d x 48" h | 24" w x 96" l   | 120V / 13.5 amps | 140,000 | 1150 lbs.         |

\* Single oven on 23" legs.