

# Wood Stone

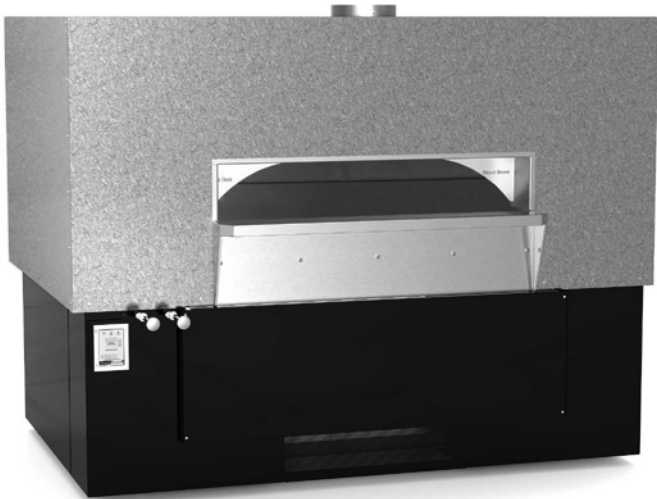

## COAL-FIRED OVEN

Fire Deck 11275-CL



### Job Name

### Model

WS-FD-11275-CL

### Item#

### Fuel Type

Gas/Coal Combination

### Hearth Capacity

8" pizzas	56
10" pizzas	35
12" pizzas	48
16" pizzas	12
18" pizzas	12

Assuming 5-minute cook times, the approximate maximum hourly production capacity can be calculated by multiplying the above numbers by 12.

### OPTIONAL ACCESSORIES

- Decorative Flame
- Stainless Steel Storage Boxes
- Stainless Steel Oven Tool Set (with stainless steel hangers)
- Stack-Mounted Exhaust Fan
- Custom Oven-Mounted Exhaust Hood
- Prepared for facade application
- Wood Stone also carries a full line of accessories for stone hearth cooking

The Fire Deck 11275 features a standard door opening 54 inches wide x 10 inches high. The cooking surface provides 32.5 square feet of usable deck space. The dense, high temperature ceramic formulation of which the hearth and dome are cast creates a "deep heat sink" within the chamber of the oven.

The monolithic, cast-ceramic floor sits on 4 inches of rigid insulation and is poured to a thickness of 6 inches. The dome is also cast to a thickness of 4 inches. The hearth and dome are connected by a carefully tensioned steel exoskeleton, which ensures structural integrity and long life.

The oven's ceramic dome is wrapped with at least 2 inches of spun ceramic fiber insulation and enclosed (front, top and sides) with 16-gauge galvanized steel. The body of the oven rests on a 10-gauge steel pan welded to a heavy-duty frame. The oven arrives completely assembled and equipped with a set of temporary rigging casters to aid in moving the oven into place.

The oven vents through a 12-inch O.D. flue collar located above the doorway. The Fire Deck 11275 can be connected directly to a power-ventilated grease rated duct, or it can be vented using a Listed Type 1 exhaust hood or one constructed in accordance with NFPA 96 and all relevant local and national codes.

**IMPORTANT** - Ovens with model numbers containing a -W or -CL must be vented as a solid fuel appliance. The oven can be installed with only 1-inch side clearance to combustible construction.



Intertek  
ANSI Z83.11b-2009  
CSA 1.8b-2009



Intertek  
ANSI/NSF STD 4

## Wood Stone

An ongoing program of product improvement may require us to change specifications without notice.  
Revised October 2011

### WOOD STONE CORPORATION

1801 W. Bakerview Rd.  
Bellingham, WA 98226 USA

Toll Free (800) 988-8103

Tel (360) 650-1111

Fax (360) 650-1166

[info@woodstone-corp.com](mailto:info@woodstone-corp.com) or visit [woodstone-corp.com](http://woodstone-corp.com)



# COAL-FIRED OVEN

Fire Deck 11275-CL

Model  
WS-FD-11275-CL

### Front View

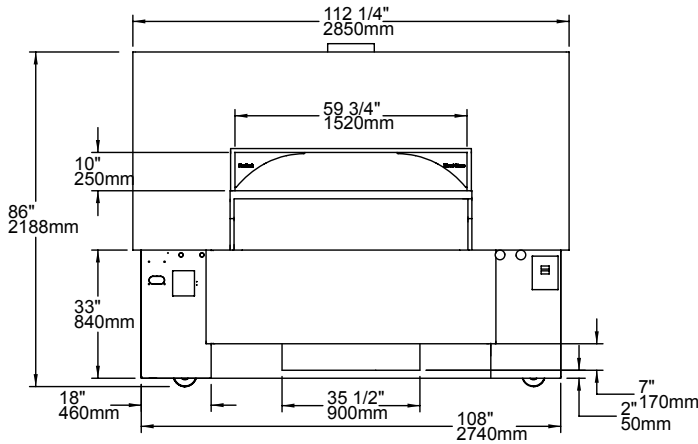

### Top View

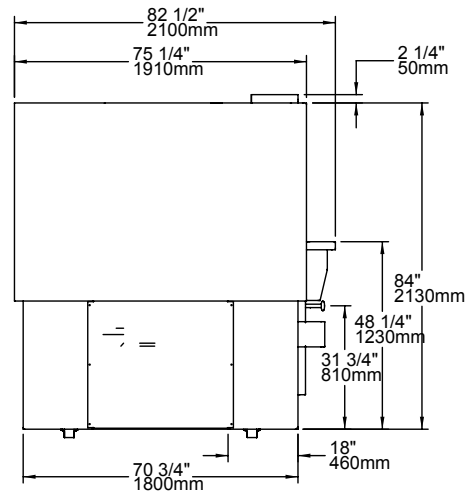

### Side View

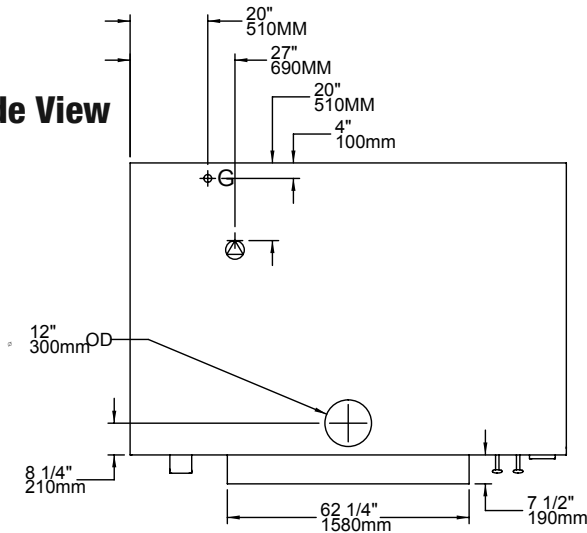

### Iso View

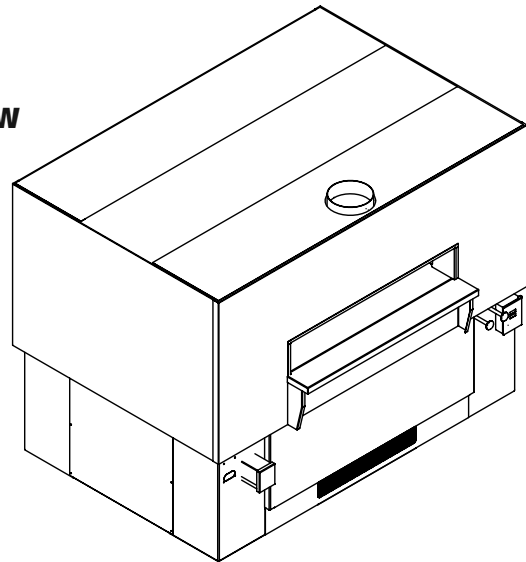

#### UTILITIES REQUIRED

1. 120 VAC/ 4 AMP electrical connection
2. 295,000 BTU/HR Natural Gas  
282,500 BTU/HR Propane (LP)  
*The oven's gas inlet is 1" N.P.T. Female*
3. Decorative Flame Burner adds 15,000 BTU's

#### VENTING INFORMATION

The Fire Deck 11275 can be direct connected to a power-ventilated, grease-rated chimney or can be vented with a Listed Type 1 exhaust hood, or one constructed in accordance with NFPA 96 and all relevant local and national codes. The oven must be vented in accordance with all relevant local and national codes, and in a manner acceptable to the authority having jurisdiction.

**IMPORTANT** - This oven must be vented as a solid fuel appliance.

**Unit Shipping Weight: 9,500 lbs.**



**Intertek**  
ANSI Z83.11b-2009  
CSA 1.8b-2009



**Intertek**  
ANSI/NSF STD 4

**Wood Stone**

An ongoing program of product improvement may require us to change specifications without notice.  
**Revised October 2011**

#### WOOD STONE CORPORATION

1801 W. Bakerview Rd.  
Bellingham, WA 98226 USA

[info@woodstone-corp.com](mailto:info@woodstone-corp.com) or visit [woodstone-corp.com](http://woodstone-corp.com)

Toll Free (800) 988-8103

Tel (360) 650-1111

Fax (360) 650-1166