

Wood Stone



Oven shown with optional stainless steel mantle.

Hearth Capacity

8" pizzas	36-40
10" pizzas	22-26
12" pizzas	16-20
16" pizzas	8-10

Assuming 5-minute cook times, the approximate maximum hourly production capacity can be calculated by multiplying the above numbers by 12.

OPTIONAL ACCESSORIES

- Doorway and Service Panel Extensions
- Stainless Steel or Black Granite Mantles
- Decorative Oven-Mounted Wood box
- Stainless Steel Oven Tools
- Custom Finishes
- Exhaust Fan
- Exhaust Hood
- Wood Burning Option
- Custom Wood Burning Accessories
- Multiple Opening Option

MT. RAINIER 7'

Stone Hearth Oven



Job Name

Model WS-MS-7-RFG-IR

Item#

Fuel Type **Dual Burner, Gas-Fired**

The Mt. Rainier Dual Burner, Gas-Fired oven features a standard door opening 42 inches wide x 12 inches high. The inside diameter of the oven floor is 74 inches, resulting in a 31-square-foot cooking surface. The oven is ETL Listed for installation with only 1-inch side clearance to combustible building materials.

The dense, high-temperature ceramic formulation of which the hearth and dome are cast creates a "deep heat sink" within the chamber of the oven. The oven is heated by an easily adjustable (123,000 BTU-max.) wall of radiant flame located at the rear of the cooking chamber.

The 2,000-pound, monolithic, 4-inch thick, cast-ceramic floor sits on 4 inches of rigid insulation. The 1800-pound, monolithic dome is also cast to a thickness of 4-inches. The hearth and dome are connected and supported by a carefully tensioned steel exoskeleton, which ensures structural integrity and long life. The body of the oven rests on a 12-gauge steel pan bolted to a heavy-duty, 3-inch angle iron stand. The oven is wrapped with at least 2 inches of spun ceramic fiber insulation and enclosed (top and sides) with 16-gauge galvanized steel. The oven arrives completely assembled and ready to set in place.

The oven vents through a flue collar located above the doorway. The Mt. Rainier can be direct connected to a power-ventilated, grease-rated chimney or can be vented with a Listed Type 1 exhaust hood, or one constructed in accordance with NFPA 96 and all relevant local and national codes. The oven must be vented in accordance with all relevant local and national codes and in a manner acceptable to the authority having jurisdiction. Ovens ordered without a hood will have a round flue adapter installed to facilitate direct connection to a round duct. A flue adapter is necessary only when the oven will be direct connected.

The Mt. Rainier Radiant Flame, Gas-Fired oven can be manufactured to be fully and easily convertible to a Dual Burner Gas-Fired oven (this must be specified at time of order).



Wood Stone

An ongoing program of product improvement may require us to change specifications without notice.
Revised July 2010

WOOD STONE CORPORATION

1801 W. Bakerview Rd.
Bellingham, WA 98226 USA

Toll Free (800) 988-8103

Tel (360) 650-1111

Fax (360) 650-1166

info@woodstone-corp.com or visit www.woodstone-corp.com



MT. RAINIER 7'

Stone Hearth Oven

Model
WS-MS-7-RFG-IR

Front View

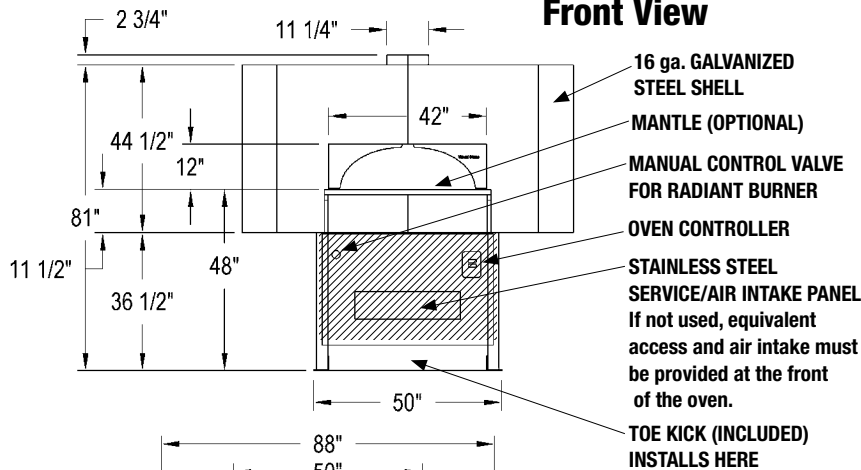

Top View

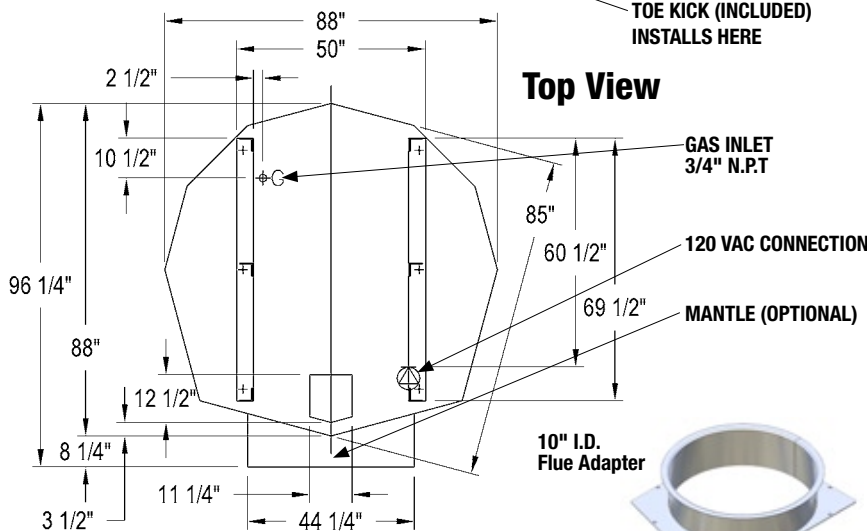

Side View

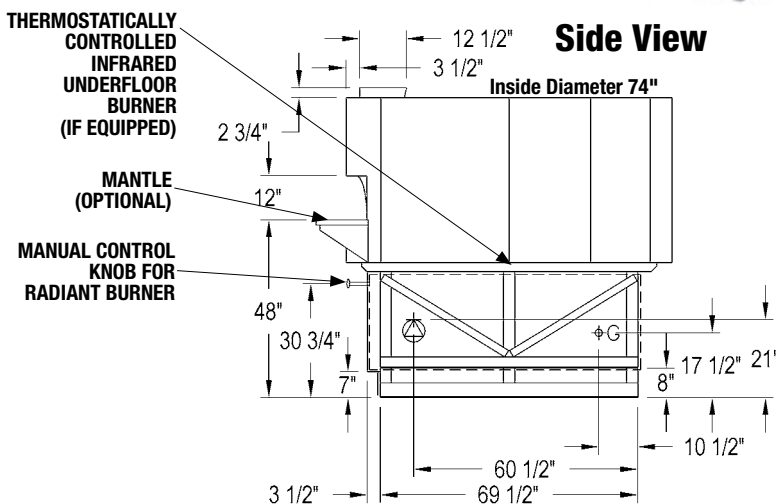

UTILITIES REQUIRED

1. 120-VAC/ 1.1-AMP Electrical Supply
2. 220,000-BTU Natural Gas Supply OR 227,000-BTU Propane (LP) Supply

FACADE INFORMATION

1. All facades or enclosures are by others; see installation information for details.
2. Any facade or enclosure below the mantle allow the following:

- a) Unobstructed access 23 inches to each side of centerline for removal of service / intake panel.
- b) Easy access to all controls.
- c) Sufficient combustion air for gas burners; see installation information for details.

VENTING INFORMATION

The Mt. Rainier can be direct connected to a power-ventilated, grease-rated chimney or can be vented with a Listed Type 1 exhaust hood, or one constructed in accordance with NFPA 96 and all relevant local and national codes. The oven must be vented in accordance with all relevant local and national codes and in a manner acceptable to the authority having jurisdiction. Ovens ordered without a hood will have a round flue adapter installed to facilitate direct connection to a round duct. A flue adapter is necessary only when the oven will be direct connected.

**Unit Shipping Weight:
6,000 lbs.**



Wood Stone

An ongoing program of product improvement may require us to change specifications without notice.
Revised July 2010

WOOD STONE CORPORATION

1801 W. Bakerview Rd.
Bellingham, WA 98226 USA

Toll Free (800) 988-8103

Tel (360) 650-1111

Fax (360) 650-1166

info@woodstone-corp.com or visit www.woodstone-corp.com