

Wood Stone



Oven shown with optional stainless steel mantle and optional storage box.

MT. CHUCKANUT 4'

Stone Hearth Oven



Job Name	
Model	WS-MS-4-W
Item#	
Fuel Type	Wood-Fired

The Mt. Chuckanut features a standard door opening 20 inches wide x 10 inches high. The inside diameter of the oven floor is 37 inches, resulting in a 9-square-foot cooking surface. The Mt. Chuckanut is approved for installation with only 1-inch side clearance to combustible building materials.

The hearth and dome of the oven are cast using a very dense, deep heat sink refractory formulation. The 650-pound, monolithic, 4-inch thick cast-ceramic floor sits on 4 inches of rigid insulation. The 700-pound, monolithic dome is also cast to a thickness of at least 4 inches. The hearth and dome are connected and supported by a carefully tensioned steel exoskeleton, which ensures structural integrity and long life. The body of the oven rests on a 12-gauge steel pan bolted to a heavy-duty, 3-inch angle iron stand. The oven is wrapped with at least 2 inches of spun ceramic fiber insulation and enclosed (top and sides) with 16-gauge galvanized steel. The oven arrives completely assembled and ready to set in place.

The removable thermocouple is centered and installed into the underside of the hearth to within 1-inch of the cooking surface. The digital thermometer readout can be mounted to the oven stand or incorporated into the decorative facade, at the discretion of the designer.

The oven vents through an 8-inch O.D. flue collar located above the doorway. The Mt. Chuckanut can be direct connected to a power-ventilated, grease-rated chimney or can be vented with a Listed Type 1 exhaust hood, or one constructed in accordance with NFPA 96 and all relevant local and national codes. The oven must be vented as a solid fuel appliance, in accordance with all relevant local and national codes, and in a manner acceptable to the authority having jurisdiction.

All Wood Stone, Wood-Fired ovens are designed to be easily and fully convertible to Dual Burner, Gas-Fired ovens. *This must be specified at the time of order.*

Hearth Capacity

8" pizzas	8-10
10" pizzas	5-6
12" pizzas	4
16" pizzas	1-2

Assuming 5-minute cook times, the approximate maximum hourly production capacity can be calculated by multiplying the above numbers by 12.

Note: Highlighted capacities are considered an operational challenge.

OPTIONAL ACCESSORIES

- Doorway and Storage Box Extensions
- Adjustable Wood Storage Box
- Moisture Meter for Testing Firewood Quality
- Mobile Wood Cart
- Stainless Steel Oven Tools
- Stainless Steel Ash Dolly
- Custom Finishes
- Exhaust Hood
- Exhaust Fan
- Custom Wood Burning Accessories



An ongoing program of product improvement may require us to change specifications without notice.
Revised June 2011

WOOD STONE CORPORATION
1801 W. Bakerview Rd.
Bellingham, WA 98226 USA

Toll Free (800) 988-8103
Tel (360) 650-1111
Fax (360) 650-1166

info@woodstone-corp.com or visit www.woodstone-corp.com



MT. CHUCKANUT 4'

Stone Hearth Oven

Model

WS-MS-4-W

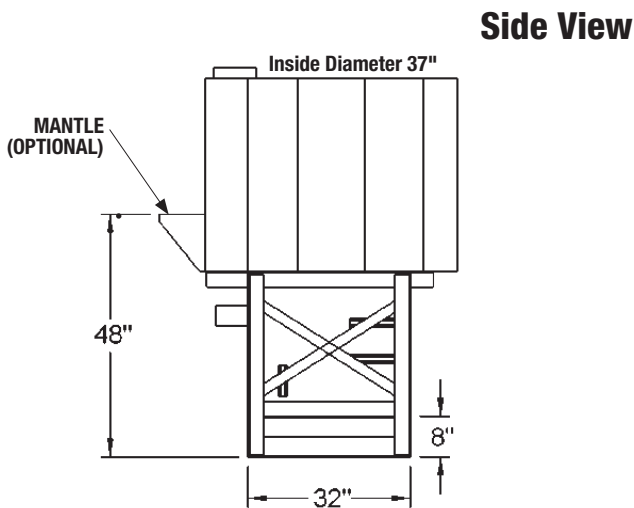
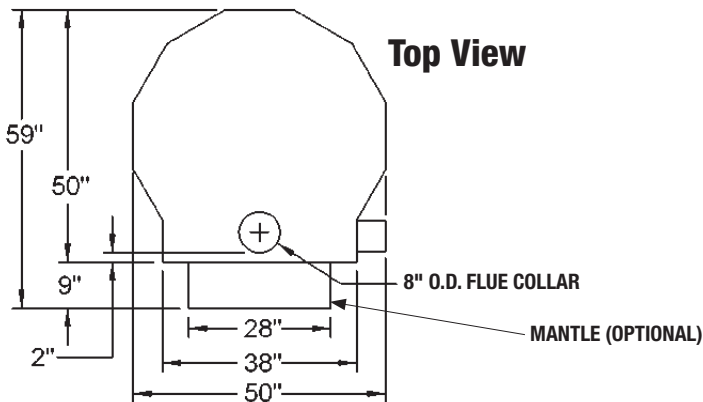
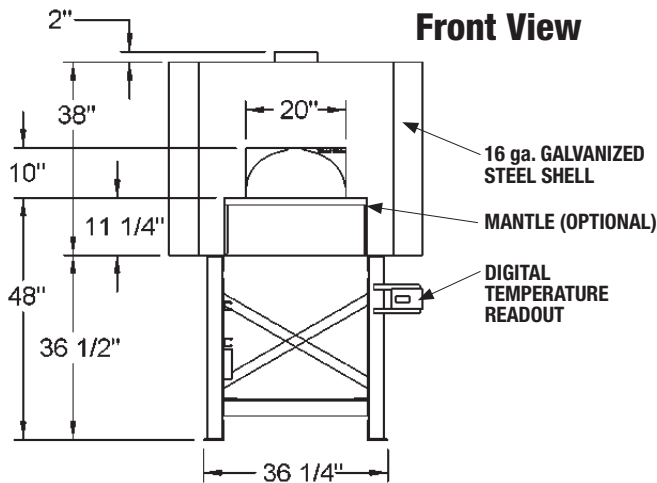

UTILITIES REQUIRED

120-VAC/ 0.3-AMP Electrical Supply-
Connection made at readout box.

FACADE INFORMATION

All facades or enclosures are by others; see installation information for details.

VENTING INFORMATION

The Mt. Chuckanut can be direct connected to a power-ventilated, grease-rated chimney or can be vented using a Listed Type 1 exhaust hood or one constructed in accordance with NFPA 96 and all relevant local and national codes. The oven must be vented as a solid fuel appliance, in accordance with all relevant local and national codes, and in a manner acceptable to the authority having jurisdiction.

**Unit Shipping Weight:
2,400 lbs.**



Wood Stone

An ongoing program of product improvement may require us to change specifications without notice.
Revised June 2011

WOOD STONE CORPORATION
1801 W. Bakerview Rd.
Bellingham, WA 98226 USA

Toll Free (800) 988-8103
Tel (360) 650-1111
Fax (360) 650-1166

info@woodstone-corp.com or visit www.woodstone-corp.com