

# Wood Stone



Oven shown with optional stainless steel mantle.

## Hearth Capacity

8" pizzas	18-22
10" pizzas	14-16
12" pizzas	10-12
16" pizzas	6-8

Assuming 5-minute cook times, the approximate maximum hourly production capacity can be calculated by multiplying the above numbers by 12.

## OPTIONAL ACCESSORIES

- Doorway and Service Panel Extensions
- Stainless Steel or Black Granite Mantles
- Adjustable Wood Storage Box
- Moisture Meter for Testing Firewood Quality
- Mobile Wood Cart
- Stainless Steel Oven Tools
- Custom Finishes
- Exhaust Fan/ Exhaust Hood
- Multiple Opening Option

## MT. BAKER 6'

Stone Hearth Oven



<b>Job Name</b>	
<b>Model</b>	WS-MS-6-W
<b>Item#</b>	
<b>Fuel Type</b>	<b>Wood-Fired</b>

The Mt. Baker Wood-Fired oven features a standard door opening 36 inches wide x 10 inches high. The inside diameter of the oven floor is 62 inches, resulting in a 22-square-foot cooking surface. The Mt. Baker is approved for installation with only 1-inch side clearance to combustible building materials.

The hearth and dome of the oven are cast using a very dense, deep heat sink refractory formulation. The 1,600-pound, monolithic, 4-inch thick, cast-ceramic floor sits on 4 inches of rigid insulation. The 1,300-pound, monolithic dome is also cast to a thickness of 4 inches. The hearth and dome are connected and supported by a carefully tensioned steel exoskeleton, which ensures structural integrity and long life. The body of the oven rests on a 12-gauge steel pan bolted to a heavy-duty, 3-inch angle iron stand. The oven is wrapped with at least 2 inches of spun ceramic fiber insulation and enclosed (top and sides) with 16-gauge galvanized steel. The oven arrives completely assembled and ready to set in place.

The removable thermocouple is centered and cast into the underside of the hearth to within 1-inch of the cooking surface. The digital thermometer readout can be mounted to the oven stand or incorporated into the decorative facade, at the discretion of the designer.

The oven vents through a flue collar located above the doorway. The Mt. Baker can be direct connected to a power-ventilated, grease-rated chimney or can be vented with a Listed Type 1 exhaust hood, or one constructed in accordance with NFPA 96 and all relevant local and national codes. The oven must be vented as a solid fuel appliance in accordance with all relevant local and national codes and in a manner acceptable to the authority having jurisdiction. Ovens ordered without a hood will have a round flue adapter installed to facilitate direct connection to a round duct. A flue adapter is necessary only when the oven will be direct connected. Models that utilize wood as a fuel source must be vented as a solid fuel appliance.

All Wood Stone, Wood-Fired ovens are designed to be easily and fully convertible to Radiant-Flame, Gas-Fired ovens.



**Wood Stone**

An ongoing program of product improvement may require us to change specifications without notice.  
Revised July 2010

**WOOD STONE CORPORATION**  
1801 W. Bakerview Rd.  
Bellingham, WA 98226 USA

Toll Free (800) 988-8103  
Tel (360) 650-1111  
Fax (360) 650-1166

[info@woodstone-corp.com](mailto:info@woodstone-corp.com) or visit [www.woodstone-corp.com](http://www.woodstone-corp.com)



# MT. BAKER 6'

Stone Hearth Oven

Model

# WS-MS-6-W

### Front View

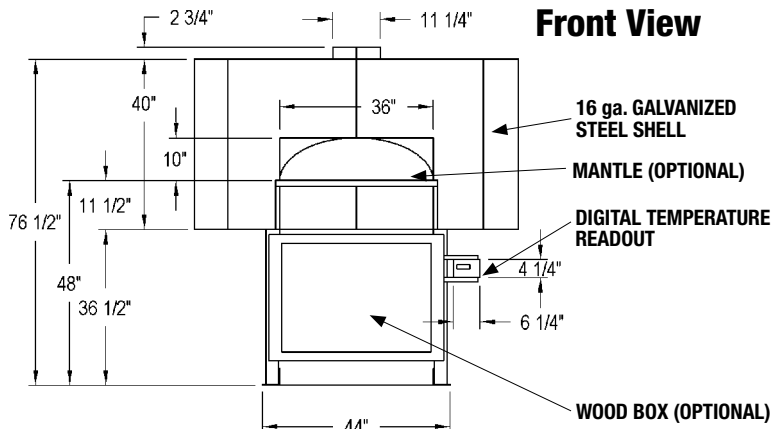

### Top View

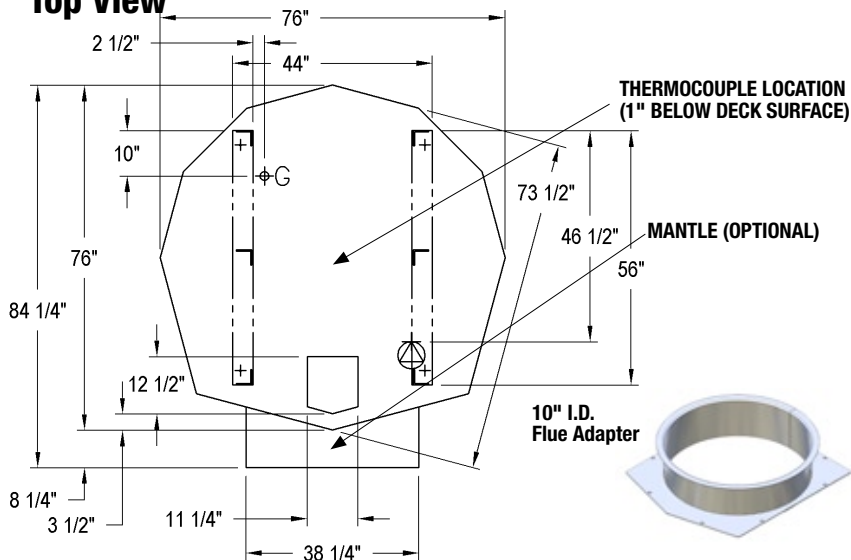

### Side View

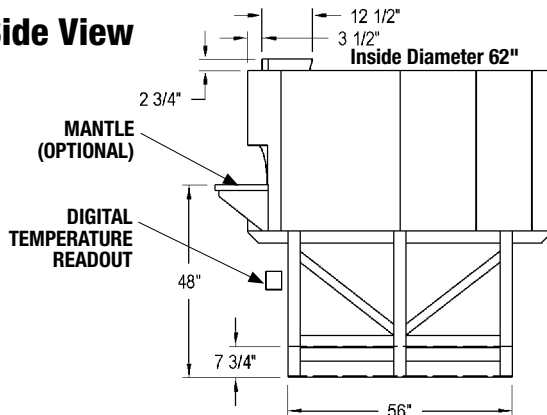

### UTILITIES REQUIRED

120-VAC/ 1.1-AMP Electrical Supply

### FACADE INFORMATION

All facades or enclosures are by others; see installation information for details

### VENTING INFORMATION

The oven vents through a flue collar located above the doorway. The Mt. Baker can be direct connected to a power-ventilated, grease-rated chimney or can be vented with a Listed Type 1 exhaust hood, or one constructed in accordance with NFPA 96 and all relevant local and national codes. The oven must be vented as a solid fuel appliance in accordance with all relevant local and national codes and in a manner acceptable to the authority having jurisdiction. Ovens ordered without a hood will have a round flue adapter installed to facilitate direct connection to a round duct. A flue adapter is necessary only when the oven will be direct connected. Models that utilize wood as a fuel source must be vented as a solid fuel appliance.

**Unit Shipping Weight:  
4,600 lbs.**



An ongoing program of product improvement may require us to change specifications without notice.  
Revised July 2010

### WOOD STONE CORPORATION

1801 W. Bakerview Rd.  
Bellingham, WA 98226 USA

Toll Free (800) 988-8103

Tel (360) 650-1111

Fax (360) 650-1166

[info@woodstone-corp.com](mailto:info@woodstone-corp.com) or visit [www.woodstone-corp.com](http://www.woodstone-corp.com)