

Wood Stone



Oven shown with optional stainless steel mantle.

MT. ADAMS 5'

Stone Hearth Oven



Job Name	
Model	WS-MS-5-RFG-IR-W
Item#	
Fuel Type	Dual Burner, Gas-Fired / Wood Optional

The Mt. Adams Dual Burner, Gas-Fired / Wood Optional oven features a standard door opening 30 inches wide x 10 inches high. The inside diameter of the oven floor is 52 inches, resulting in a 15-square-foot cooking surface. The oven is approved for installation with a 1-inch side clearance to combustible building materials.

The dense, high-temperature ceramic formulation of which the hearth and dome are cast creates a "deep heat sink" within the chamber of the oven. The oven is primarily heated by an easily adjustable (105,000-BTU max.) wall of radiant flame located at the rear of the cooking chamber. An 83,000-BTU thermostatically controlled infrared burner mounted under the floor ensures constant deck temperatures. The combined effect of these heat sources makes the Mt. Adams a very powerful and responsive stone hearth oven. The user also has the option of building a small wood fire on either side of the cooking chamber for additional ambience and flavor.

The 1,100-pound, monolithic, 4-inch thick, cast-ceramic floor sits on 4 inches of rigid insulation. The 1,100-pound, monolithic dome is also cast to a thickness of at least 4 inches. The hearth and dome are connected and supported by a carefully tensioned steel exoskeleton, which ensures structural integrity and long life. The body of the oven rests on a 12-gauge steel pan bolted to a heavy-duty, 3-inch angle iron stand. The oven is wrapped with at least 2 inches of spun ceramic fiber insulation and enclosed (top and sides) with 16-gauge galvanized steel. The oven arrives completely assembled and ready to set in place.

The oven vents through a flue collar located above the doorway. The Mt. Adams can be direct connected to a power-ventilated, grease-rated chimney or can be vented with a Listed Type 1 exhaust hood, or one constructed in accordance with NFPA 96 and all relevant local and national codes. The oven must be vented as a solid fuel appliance in accordance with all relevant local and national codes, and in a manner acceptable to the authority having jurisdiction. Ovens ordered without a hood will have a round flue adapter installed to facilitate direct connection to a round duct. A flue adapter is necessary only when the oven will be direct connected. Models that utilize wood as a fuel source must be vented as a solid fuel appliance.

Hearth Capacity*	
8" pizzas	12-16
10" pizzas	10-12
12" pizzas	8
16" pizzas	5

***May vary when an optional wood fire is burned in the oven.**

Assuming 5-minute cook times, the approximate maximum hourly production capacity can be calculated by multiplying the above numbers by 12.

Note: Highlighted capacities are considered an operational challenge.

OPTIONAL ACCESSORIES

- Doorway and Service Panel Extensions
- Stainless Steel or Black Granite Mantles
- Stainless Steel Oven Tools
- Custom Finishes
- Exhaust Fan
- Exhaust Hood
- Custom Wood Burning Accessories
- Multiple Opening Option



An ongoing program of product improvement may require us to change specifications without notice.
Revised December 2010

WOOD STONE CORPORATION
1801 W. Bakerview Rd.
Bellingham, WA 98226 USA

Toll Free (800) 988-8103
Tel (360) 650-1111
Fax (360) 650-1166

info@woodstone-corp.com or visit www.woodstone-corp.com



MT. ADAMS 5'

Stone Hearth Oven

Model
WS-MS-5-RFG-IR-W

UTILITIES REQUIRED

Gas and Wood Gas Combination Ovens

1. 120-VAC/ 1.1-AMP Electrical Supply
2. 188,000-BTU Natural Gas Supply
OR
159,000-BTU Propane (LP) Supply

FACADE INFORMATION

1. All facades or enclosures are by others; see installation information for details.
2. Any facade or enclosure below the mantle allow the following:
 - a) Unobstructed access 17 inches to each side of centerline for removal of service/intake panel.
 - b) Easy access to all controls.
 - c) Sufficient combustion air for gas burners; see installation information for details.

VENTING INFORMATION

The oven vents through a flue collar located above the doorway. The Mt. Adams can be direct connected to a power-ventilated, grease-rated chimney or can be vented with a Listed Type 1 exhaust hood, or one constructed in accordance with NFPA 96 and all relevant local and national codes. The oven must be vented as a solid fuel appliance in accordance with all relevant local and national codes, and in a manner acceptable to the authority having jurisdiction. This oven must be vented as a solid fuel appliance. Ovens ordered without a hood will have a round flue adapter installed to facilitate direct connection to a round duct. A flue adapter is necessary only when the oven will be direct connected. Models that utilize wood as a fuel source must be vented as a solid fuel appliance.

**Unit Shipping Weight:
3,600 lbs.**

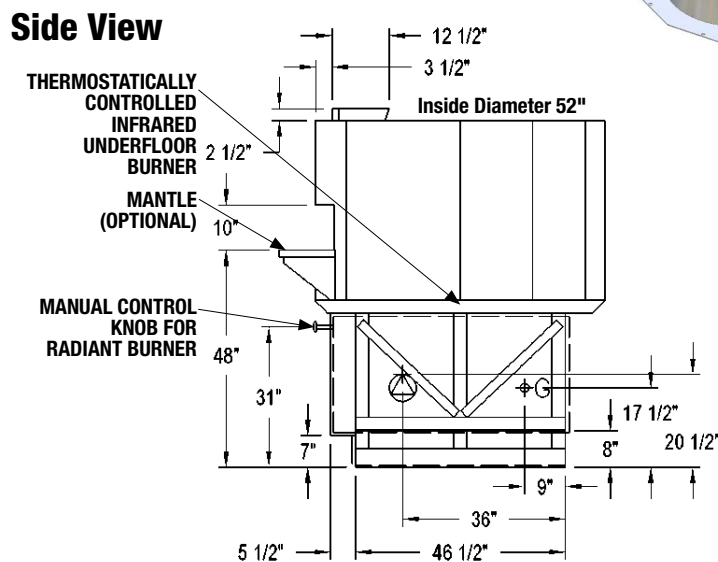
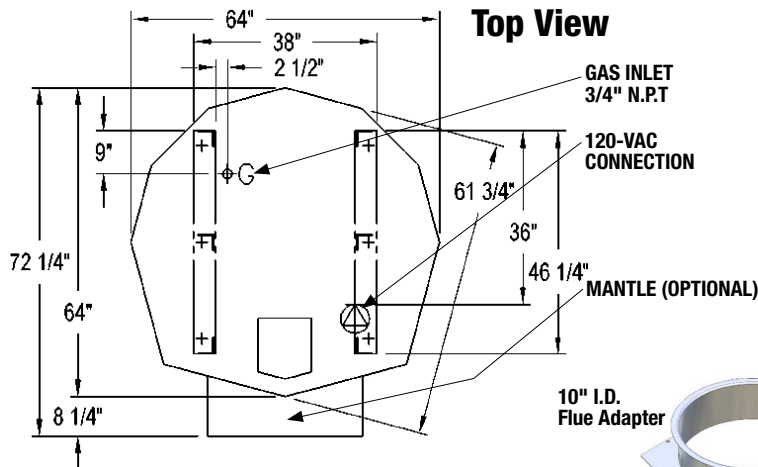
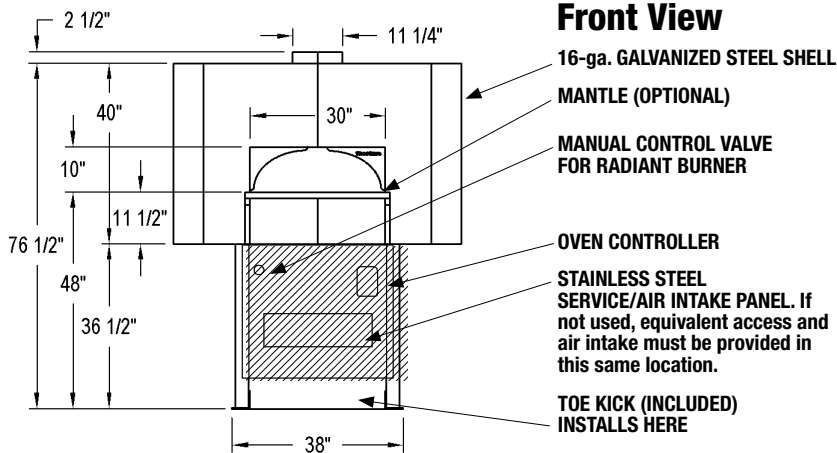

An ongoing program of product improvement may require us to change specifications without notice.
Revised December 2010

WOOD STONE CORPORATION
1801 W. Bakerview Rd.
Bellingham, WA 98226 USA

Toll Free (800) 988-8103
Tel (360) 650-1111
Fax (360) 650-1166

info@woodstone-corp.com or visit www.woodstone-corp.com